

# Contents

---

<b>Preface</b> .....	<b>1</b>
<b>Introduction</b> .....	<b>1</b>
Owner's Handbook .....	1
Announcement .....	1
Prompt Messages .....	3
<b>Vehicle Identification Information</b> .....	<b>4</b>
Vehicle Identification .....	4
Vehicle Identification Plate .....	5
<b>1 Instruments and Controls</b> .....	<b>7</b>
<b>Instruments and Controls</b> .....	<b>8</b>
<b>Instrument Pack</b> .....	<b>10</b>
Instrument Pack - Colour Display A * .....	10
Instrument Pack - Colour Display B * .....	11
<b>Information Centre</b> .....	<b>13</b>
Information Centre - Colour Display A * .....	13
Information Centre - Colour Display B * .....	20
<b>Warning Lights and Indicators</b> .....	<b>28</b>
<b>Lights and Switches</b> .....	<b>35</b>

---

Master Lighting Switch .....	35
Headlamp Levelling Manual Adjustment .....	37
Fog Lamp Switch.....	38
Direction Indicator/Main Beam Switch.....	39
Auxiliary Lighting System * .....	40
Hazard Warning Lamp.....	40
<b>Wipers and Washers.....</b>	<b>41</b>
Windscreen Wiper Operation .....	41
Programmed Wash/Wipe .....	42
Rear Window Wiper Operation .....	43
<b>Steering System .....</b>	<b>45</b>
Adjustment of Steering Column .....	45
Electric Power Steering .....	46
<b>Horn .....</b>	<b>47</b>
<b>Mirrors .....</b>	<b>48</b>
Door Mirrors .....	48
Interior Rearview Mirror .....	50
<b>Sunvisors .....</b>	<b>51</b>
<b>Windows .....</b>	<b>52</b>

---

Power Operated Window Switch .....	52
Window Operation .....	52
<b>Sunroof *</b> .....	<b>54</b>
Instructions .....	54
Sunroof Operation.....	55
<b>Interior Lights</b> .....	<b>59</b>
<b>Power Socket</b> .....	<b>60</b>
<b>Storage Devices</b> .....	<b>62</b>
Instructions .....	62
Glove Box .....	62
Card Box .....	63
Centre Console Armrest Box .....	63
Glasses Box * .....	63
Loadspace .....	64
<b>Cup Holder</b> .....	<b>66</b>
Centre Console Cup Holder (EPB) .....	66
Centre Console Cup Holder (IPB) .....	66
<b>Roof Luggage Rack *</b> .....	<b>67</b>
Maximum Authorised Load for the Roof.....	67

---

Periodical Check.....	67
<b>2 Air Conditioning and Audio Systems .....</b>	<b>69</b>
<b>Ventilation .....</b>	<b>70</b>
A/C Particle/Pollen Filter .....	71
Vents .....	71
<b>Electronic Temperature Control .....</b>	<b>73</b>
Infotainment Screen Control Interface .....	73
Control Panel .....	76
A/C Display.....	78
<b>Entertainment Player * .....</b>	<b>79</b>
Important Safety Information .....	79
Cautions for Using Screen .....	80
Basic Operations .....	80
Bluetooth Phone.....	86
Entertainment .....	93
Vehicle-Mobile Phone Interconnection * .....	100
A/C .....	101
Vehicle Settings.....	101
Settings.....	102



---

<b>3 Seats &amp; Restraints</b> .....	<b>105</b>
<b>Seats</b> .....	<b>106</b>
Overview .....	106
Head Restraints .....	106
Front Seats .....	107
Rear Seats .....	109
Front Seat Heating * .....	110
<b>Seat Belts</b> .....	<b>111</b>
Protection Provided by Seat Belts .....	112
Wearing Seat Belts .....	113
Children and Seat Belts .....	117
Seat Belt Pre-tensioners .....	118
Seat Belt Checks, Maintenance and Replacement.....	119
<b>Airbag Supplementary Restraint System</b> .....	<b>121</b>
Overview .....	121
Airbag Deployment.....	122
Conditions in Which Airbags Will Not Deploy .....	125
Service and Replacement of Airbags .....	126
Disposal of Airbags .....	127

---

<b>Child Restraints</b> .....	<b>129</b>
Important Safety Instructions about Using Child Restraints .....	129
Child Restraints Groups .....	131
Approved Child Restraint Positions .....	134
<b>4 Starting &amp; Driving</b> .....	<b>139</b>
<b>Keys</b> .....	<b>140</b>
Overview .....	140
Replacing the Battery .....	141
<b>Child Proof Locks</b> .....	<b>143</b>
<b>Alarm System</b> .....	<b>144</b>
Engine Immobilisation.....	144
Anti-theft System.....	145
Tailgate .....	148
<b>Starting and Stopping Engine</b> .....	<b>150</b>
START/STOP Switch .....	150
Starting the Engine .....	151
Precautions for Starting the Engine.....	153
Stopping the Engine.....	154

---

<b>Economical and Environmental Driving .....</b>	<b>156</b>
Running-in .....	156
Environment Protection .....	156
Driving Style .....	156
Fuel Saving and Extending Vehicle Life .....	157
Maintenance .....	159
<b>Catalytic Converter .....</b>	<b>160</b>
<b>Fuel System .....</b>	<b>162</b>
Fuel Requirements .....	162
Fuel Filler .....	163
Refueling .....	163
<b>6-Speed Automatic Transmission * .....</b>	<b>164</b>
Instructions .....	164
Gear Shift .....	164
Driving on the Hill .....	167
Control Mode .....	168
<b>Continuously Variable Automatic Transmission * .....</b>	<b>171</b>
Instructions .....	171
Gear Shift .....	171

---

Driving on Hills.....	174
Control Modes .....	175
<b>Manual Transmission *</b> .....	<b>177</b>
5-speed Manual Transmission .....	177
<b>Brake System.....</b>	<b>179</b>
Foot Brake .....	179
Electronic Brake Force Distribution (EBD) .....	179
Electronic Brake Assistance (EBA) .....	180
Hill Hold Control (HHC) .....	180
Hill Descent Control (HDC) .....	181
Anti-lock Brake System (ABS).....	183
Auto Hold * .....	185
Emergency Braking Hazard Warning Lights Control (HAZ) .....	187
Active Rollover Protection (ARP).....	187
Parking Brake * .....	188
Electronic Parking Brake (EPB) * .....	189
<b>Stability Control System (SCS) and Traction Control System (TCS).....</b>	<b>191</b>
<b>Cruise Control System *</b> .....	<b>193</b>
<b>Active Speed Limit (ASL) System *</b> .....	<b>196</b>

---

Activate .....	196
Suspend ASL.....	197
Resume ASL.....	197
Exit ASL.....	197
<b>Parking Aid System.....</b>	<b>198</b>
Ultrasonic Sensor Parking Aid .....	198
Parking Camera System * .....	199
360 Panoramic Imaging System * .....	200
<b>Rear Driver Assistance System * .....</b>	<b>202</b>
System Overview.....	202
Switching the System Functions On/Off .....	203
System Functions .....	204
<b>Tyre Pressure Monitoring System (TPMS).....</b>	<b>208</b>
<b>Loading.....</b>	<b>210</b>
Trunk Loading.....	210
Internal Loading.....	210
<b>5 Emergency Information .....</b>	<b>213</b>
<b>Hazard Warning Devices .....</b>	<b>214</b>

---

Hazard Warning Lights .....	214
Warning Triangle.....	214
<b>Emergency Starting .....</b>	<b>215</b>
Using Booster Cables.....	215
Starting the Car .....	215
<b>Vehicle Recovery .....</b>	<b>217</b>
Towing for Recovery .....	217
Transporter or Trailer with Rope .....	220
<b>Wheel Replacement .....</b>	<b>222</b>
Spare Wheel and Toolbox .....	222
Changing a Wheel.....	222
<b>Fuse Replacement.....</b>	<b>226</b>
Fuse.....	226
Fuse Box.....	226
Passenger Compartment Fuse Box.....	227
Front Compartment Fuse Box .....	229
<b>Bulb Replacement .....</b>	<b>233</b>
Bulb Specification.....	233
Bulb Replacement .....	234

---

<b>6 Maintenance</b> .....	<b>237</b>
<b>Maintenance</b> .....	<b>238</b>
Routine Maintenance.....	238
<b>Bonnet</b> .....	<b>242</b>
Opening the Bonnet.....	242
Closing the Bonnet .....	242
Bonnet Open Warning .....	242
<b>Engine Compartment</b> .....	<b>244</b>
1.5L Engine Compartment.....	244
1.3L Turbocharged Engine Compartment.....	245
<b>Engine</b> .....	<b>246</b>
1.3L Turbocharged Engine Oil .....	246
1.5L Engine Oil .....	247
Engine Oil Level Check and Top Up.....	248
Engine Oil Specification .....	249
<b>Cooling System</b> .....	<b>250</b>
Coolant Check and Top Up .....	250
Coolant Specification .....	250

---

<b>Brake</b> .....	<b>252</b>
Brake Pads .....	252
Brake Fluid Check and Top Up .....	252
Brake Fluid Specification .....	253
<b>Battery</b> .....	<b>254</b>
Battery Maintenance .....	254
Battery Replacement .....	254
<b>Washers</b> .....	<b>256</b>
Windscreen Washer Check and Top Up .....	256
Washer Nozzles .....	257
Washer Fluid Specification .....	257
<b>Wipers</b> .....	<b>258</b>
Wiper Blades .....	258
Replacing Front Wiper Blades .....	259
Replacing Rear Wiper Blades .....	260
<b>Tyres</b> .....	<b>261</b>
Overview .....	261
New Tyres .....	261
Directional Tyres .....	261



---

Tyre Life.....	261
Tyre Pressure .....	262
Driving Style.....	262
Wheel Balance.....	262
Wheel Alignment.....	262
Caring for Your Tyres.....	262
Tyre Pressure .....	263
Valves .....	263
Punctured Tyres.....	263
Tyre Wear Indicators .....	263
Replacement Tyres.....	264
Wheel Fitment Rotation.....	264
Snow Chains .....	265
<b>Cleaning and Vehicle Care.....</b>	<b>267</b>
External Car.....	267
Cleaning the Interior.....	270
<b>7 Technical Data.....</b>	<b>273</b>
<b>Technical Data Dimensions .....</b>	<b>274</b>
<b>Weights .....</b>	<b>276</b>

---

<b>Major Parameters of Engine</b> .....	<b>277</b>
<b>Dynamic Performance Parameters</b> .....	<b>279</b>
<b>Recommended Fluids and Capacities</b> .....	<b>280</b>
<b>Four-Wheel Alignment Parameter Table (Unladen)</b> .....	<b>282</b>
<b>Wheels and Tyres</b> .....	<b>282</b>
<b>Tyre Pressure (Cold)</b> .....	<b>282</b>

# Preface

---

## Introduction

### Owner's Handbook

Thank you for purchasing the SAIC Motor product. Please read this handbook carefully since the information in it may allow you to know how to operate your car safely and properly, and enjoy your driving pleasure at maximum from it.

This Handbook describes all devices and functions in this passenger car series.

This handbook includes the up-to-date product information available at the time of issuance, and the company has the full authorities to take charge of the amendments, explanations and statements of this handbook. The company aims to improve our products continuously, so the product may be altered without prior notice after the handbook is completed. For any question on the purchased vehicle or owner's handbook, please consult an Authorised Repairer.

The illustrations in the Owner's Handbook are for reference only.

The information presented in this manual may vary slightly depending on vehicle configuration, software version and sales area.

### Announcement

The Owner's Handbook and Warranty and Maintenance Manual introduces how to use your vehicle properly, precautions in use, and how to service and maintain your vehicle correctly. Meanwhile, they are intended to identify agreements between the company and owners on creation and termination for related product quality assurance liabilities as well as aftersales service rights and duties. Please read the Owner's Handbook and Warranty and the Maintenance Manual carefully before using any products of the company.

Please always use accessories, parts and oils & fluids in conformity with SAIC Motor technical specifications and quality standards and applicable to the vehicle, and maintain and service your vehicle in accordance with correct operation procedures. For better maintenance and service of your vehicle, you are recommended to consult a local Authorised Repairer. Please respect intellectual property and use genuine accessories, parts, etc. If any accessories

# Preface

---

and parts which may infringe intellectual property are used, you will probably bear corresponding legal risks and legal consequences.

The Authorised Repairer in this handbook refers to any SAIC Motor MG Authorised Repairer, which is very familiar with the service and maintenance procedure of the vehicle and related regulations and is equipped with necessary special tools and spare parts, able to provide more professional services for you.

You will lose your claim if your vehicle is damaged due to reasons such as misuse, neglect, incorrect use or any modification without approval. If a vehicle is damaged or incurs an accident due to the use of any accessories, parts or oils & fluids not in conformity with SAIC Motor technical specifications and quality standards or misuse or due to improper service and maintenance, its user will also lose his claim for damage compensation, and the company will not bear corresponding liabilities.

Various countries and regions impose strict restrictions on vehicle modification and add-on. It is not allowed to change the vehicle structure, framework or features without approval, otherwise it will affect traffic safety,

vehicle operation, vehicle registration or public security management. It will not only cause malfunction or reduce performance of the related components, but also bring the harm and life-threatening risk to the driver and the passengers if parts of the vehicle are modified or altered without permission.

No part of this publication may be reproduced, stored in a retrieval system or transmitted in the form of electronic, mechanical recording or other means without prior written permission from the company.

## Prompt Messages

### Warning



*This warning symbol identifies procedures that must be followed precisely, or information that must be considered with great care, in order to reduce the risk of personal injury or serious damage to the vehicle.*

### IMPORTANT

IMPORTANT

The matter stated here must be followed strictly, otherwise your vehicle could be damaged.

### Note

**Note:** *Suggestive statements.*



This symbol indicates parts described must be disposed of by authorised persons or bodies to protect the environment.

### Asterisk

The asterisk “\*” appeared behind a title or text indicates that the described device or function is only available on certain models, and the vehicle you purchased may not be equipped with the device or function.

### Illustration Information



Indicates the described object.



Indicates the moving direction of the object.

## Vehicle Identification Information

### Vehicle Identification

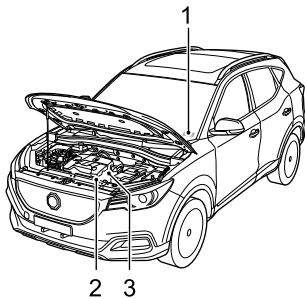

- 1 Vehicle Identification Number (VIN)
- 2 Engine Number
- 3 Transmission Number

When communicating with an MG Authorised Repairer, always quote the Vehicle Identification Number (VIN). If

the engine or transmission is involved, it may be required to provide the identification numbers of these assemblies.

### Vehicle Identification Location

#### *Vehicle Identification Number*

- Stamped on a plate visible through the bottom left hand corner of the windscreen;
- On the identification plate;
- On the floor under the front right hand seat;
- On the inner side of the tailgate visible by opening the tailgate.

**Note:** *The vehicle diagnostic socket is located under the LH side of the fascia panel. The VIN information can be accessed using the SAIC Diagnostic Scan Tool.*

#### *Engine Number Location*

Stamped on the front right of the cylinder block (View from the front of the engine).

#### *Transmission Number Location*

On the surface of the transmission housing in the engine compartment. The transmission number of some vehicles

# Preface

---

is on the rear transmission housing (viewed from the front end of the vehicle), which can be seen when the vehicle is lifted, please contact a local Authorised Repairer.

## **Vehicle Identification Plate**

The vehicle identification plate contains the following information:

- Model / Type;
- Engine Type;
- Vehicle Identification Number (VIN);
- Date;
- Gross Vehicle Weight;
- Gross Train Weight \*;
- Max Front Axle Weight \*;
- Max Rear Axle Weight \*;
- Country;
- Manufacturer.

## Location of Vehicle Identification Label

The identification label is located at the lower side of the right or left B pillar.

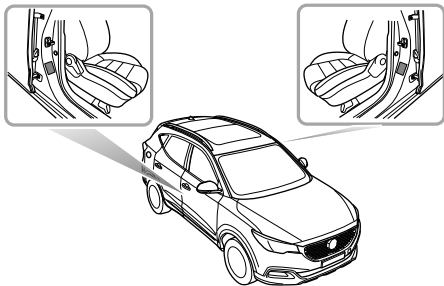



## ***Instruments and Controls***

---

- |    |                                      |    |                            |
|----|--------------------------------------|----|----------------------------|
| 8  | <i>Instruments and Controls</i>      | 60 | <i>Power Socket</i>        |
| 10 | <i>Instrument Pack</i>               | 62 | <i>Storage Devices</i>     |
| 13 | <i>Information Centre</i>            | 66 | <i>Cup Holder</i>          |
| 28 | <i>Warning Lights and Indicators</i> | 67 | <i>Roof Luggage Rack *</i> |
| 35 | <i>Lights and Switches</i>           |    |                            |
| 41 | <i>Wipers and Washers</i>            |    |                            |
| 45 | <i>Steering System</i>               |    |                            |
| 47 | <i>Horn</i>                          |    |                            |
| 48 | <i>Mirrors</i>                       |    |                            |
| 51 | <i>Sunvisors</i>                     |    |                            |
| 52 | <i>Windows</i>                       |    |                            |
| 54 | <i>Sunroof *</i>                     |    |                            |
| 59 | <i>Interior Lights</i>               |    |                            |
-

# Instruments and Controls

---

## Instruments and Controls

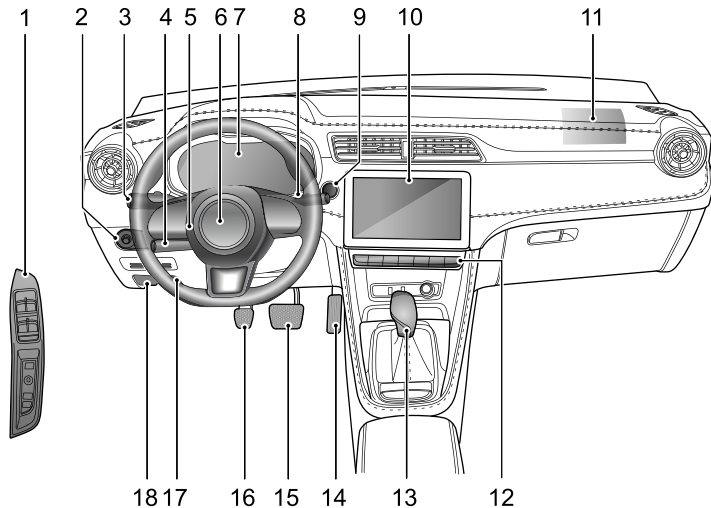

# Instruments and Controls

---

- 1 Power Window Switch
- 2 Exterior Rearview Mirror and Headlamp Leveling Switch
- 3 Indicator/Main Beam Stalk Switch
- 4 Cruise Control/ASL Stalk Switch \*
- 5 Horn Button
- 6 Driver Airbag
- 7 Instrument Pack
- 8 Wiper Stalk Switch
- 9 START/STOP Switch
- 10 Infotainment System
- 11 Front Passenger Airbag
- 12 Infotainment/Air Conditioning Control Switch
- 13 Gear Shift Lever
- 14 Accelerator Pedal
- 15 Brake Pedal
- 16 Clutch Pedal \*
- 17 Bonnet Release Handle
- 18 Fuel Filler Flap Release Handle

# Instruments and Controls

## Instrument Pack

### Instrument Pack - Colour Display A \*



#### Speedometer (1)

Indicates the vehicle speed in km/h.

#### Tachometer (2)

Indicates the engine speed,  $\times 1000$  rpm.

#### IMPORTANT

To protect the engine from damage, never allow the pointer to remain in the red sector of the gauge for prolonged periods.

#### Engine Coolant Temperature Gauge (3)

Indicates the engine coolant temperature.

#### Fuel Gauge (4)

Indicates the quantity of fuel in the tank.

The low fuel warning lamp will illuminate yellow or flash when the fuel remaining in the fuel tank is low.

#### IMPORTANT

If the low fuel warning lamp illuminates, please refuel as early as possible.



Indicates that the fuel filler is located on the right side of the vehicle.

# Instruments and Controls

## Instrument Pack - Colour Display B\*

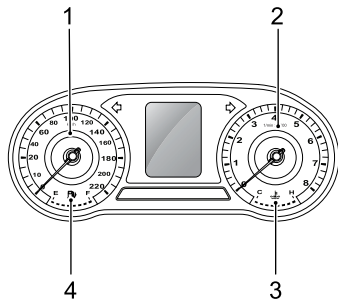

### Speedometer (1)

Indicates the vehicle speed in km/h.

### Tachometer (2)

Indicates the engine speed,  $\times 1000$  rpm.

### IMPORTANT

To protect the engine from damage, never allow the pointer to remain in the red sector of the gauge for prolonged periods.

### Engine Coolant Temperature Gauge (3)

Indicates the engine coolant temperature.

### Fuel Gauge (4)

Indicates the quantity of fuel in the tank.

The low fuel warning lamp will illuminate yellow or flash when the fuel remaining in the fuel tank is low.

### IMPORTANT

If the low fuel warning lamp illuminates, please refuel as early as possible.



Indicates that the fuel filler is located on the right side of the vehicle.

## Instruments and Controls

---

*Note: Depending on the vehicle options, software version and market area, the information displayed may vary slightly.*

## Information Centre

### Information Centre - Colour Display A \*

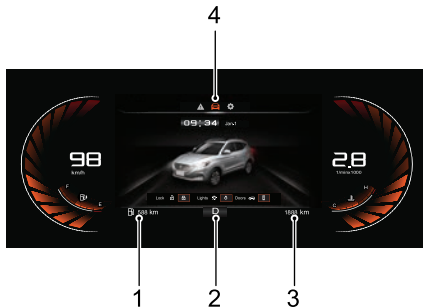

The information centre provides the followings:

- 1 Range To Empty
- 2 Gear Display \*
- 3 Total Mileage
- 4 General Information

### Range To Empty

Displays the estimated mileage that the vehicle can travel before the fuel gauge reads empty.

### Gear Display \*

Displays the current gear position of the auto transmission (P, R, N, D, S, 1, 2, 3, 4, 5, 6). If "EP" is displayed, it indicates that a fault has been detected with the transmission. Please seek an MG Authorised Repairer as soon as possible. Refer to "Starting & Driving" section.

### Total Mileage

Displays the total driving mileage of the vehicle.

### General Information

The general information function can be selected as follows:

- Press the UP/DOWN/LEFT/RIGHT button on the right hand multifunction steering wheel switch to shift the display items.

# Instruments and Controls

- Press the OK button on the right hand multifunction steering wheel switch to confirm or long press OK button to reset.
- Press the UP/DOWN button on the right hand multifunction steering wheel switch to make adjustment.



General information provides the following:

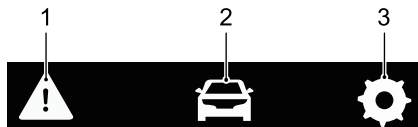

- 1 Warning Information
- 2 Trip Computer
- 3 Setting

## *Warning Information*

Displays the warning information or important notes that are currently relevant to the vehicle.

## *Trip Computer*

Trip computer functions contain the following:

- **Default Page:** displays the current status of the locks, lights and doors.
- **Current Journey:** displays the range, duration, average speed and average fuel consumption since startup. These values will be reset after a period of power off.



It can also be reset by long pressing the OK button on the right hand multifunction steering wheel switch.

- **Accumulated Total:** displays the range, duration, average speed and average fuel consumption since the last reset. It can be reset by long pressing the OK button on the right hand multifunction steering wheel switch.
- **Tyre Pressures:** displays the current tyre pressure data for each wheel.
- **Fuel Consumption Trend:** displays the fuel consumption curve of the last 50km.
- **Battery Voltage:** displays the 12V Battery Voltage.

## *Setting*

### **Brightness**

Displays the current level and allows adjustment of the backlight brightness.

### **Speed Warning**\*

Allows the setting of the over-speed alarm threshold.

### **Next Service**

Displays and facilitates the reset of the current vehicle maintenance information.

### **Warning Message**

Warning messages and prompts are displayed in the information centre in the instrument pack. Any communications are displayed in 'pop up' messages, these can be divided into the following categories:

- Operating Instruction
- System State Instruction
- System Malfunction Alert

Please follow the instructions displayed in the 'pop up' message or in the case of a warning message, please refer to the relevant section of the owners manual to follow the correct instructions.

The following are a selection of warning messages that may appear in the information centre.

## Instruments and Controls

Warning Message	Procedure
Cruise Control Fault	Indicates that the cruise control system has detected a fault. Please consult an MG Authorised Repairer as soon as possible.
Active Speed Limiter Fault	Indicates that the active speed limit system has detected a fault. Contact an MG Authorised Repairer as soon as possible.
Engine Coolant Temperature High	High engine coolant temperature could result in severe damage. As soon as conditions permit, safely stop the vehicle and switch off the engine and contact an MG Authorised Repairer immediately.
Engine Coolant Temperature Sensor Fault	Indicates that the engine coolant temperature sensor has failed. As soon as conditions permit, safely stop the vehicle and switch off the engine and contact an MG Authorised Repairer immediately.

Warning Message	Procedure
Low Oil Pressure	Indicates that the oil pressure is too low, which may result in severe engine damage. As soon as safety permits, stop the car, switch off the engine and check the engine oil level. Contact an MG Authorised Repairer as soon as possible.
Engine Fault	Indicates that a failure has occurred that will effect engine performance and emissions. Contact an MG Authorised Repairer as soon as possible.
Check Engine	Indicates that a failure has occurred that may severely damage the engine. As soon as conditions permit, safely stop the vehicle , switch off the engine and contact an MG Authorised Repairer immediately.

# Instruments and Controls

Warning Message	Procedure
Ignition System Fault	Indicates that the ignition system has detected a fault. Please consult an MG Authorised Repairer immediately.
Start Stop Button Fault	Indicates that the Start Stop button has detected a fault. Please consult an MG Authorised Repairer immediately.
Passive Entry Fault	Indicates that the passive keyless entry (PKE) function has detected a fault. Please consult an MG Authorised Repairer as soon as possible.
ABS Fault	Indicates that the anti-lock brake system (ABS) has failed and the ABS function is about to be disabled. Please consult an MG Authorised Repairer immediately.

Warning Message	Procedure
Brake Fault	Indicates that the brake fluid could be low or a fault has been detected in the Electronic Brake-force Distribution (EBD) system. As soon as safety permits, stop the car, switch off the engine and check the brake fluid level. Contact an MG Authorised Repairer as soon as possible.
Stability Control Fault	Indicates that the stability control system has detected a fault. Please consult an MG Authorised Repairer immediately.
Traction Control Fault	Indicates that the traction control system has detected a fault. Please consult an MG Authorised Repairer immediately.

## Instruments and Controls

Warning Message	Procedure
EPB System Fault	Indicates that the electronic parking brake system (EPB) has detected a fault. Please consult an MG Authorised Repairer as soon as possible.
Park Brake Force Not Enough	Indicates that there is an issue with the electronic parking brake, it may not be able to provide adequate clamping force. Contact an MG Authorised Repairer as soon as possible.
Autohold Fault	Indicates that the Autohold System has detected a fault. Please consult an MG Authorised Repairer as soon as possible.
Hill Descent Control Fault	Indicates that the hill descent control system has detected a fault. Please consult an MG Authorised Repairer as soon as possible.

Warning Message	Procedure
EPS Performance Reduced	Indicates that the electric power steering system has a general failure and that the steering performance has been reduced. As soon as conditions permit, safely stop the vehicle and switch off the engine. After a short while, start the engine, drive the vehicle a short distance and monitor the operation of the steering, if the message is still displayed or the steering assistance reduced please contact an MG Authorised Repairer immediately.
EPS Assistance Failure	Indicates that the electric power steering system has failed. Please consult an MG Authorised Repairer immediately.

## Instruments and Controls

Warning Message	Procedure
Steering Angle Fault	Indicates that the steering angle sensor has failed. Please consult an MG Authorised Repairer as soon as possible.
Steering Angle Uncalibrated	Indicates that the steering angle sensor is not calibrated. Please consult an MG Authorised Repairer as soon as possible.
Fuel Sensor Fault	Indicates that fuel sensor has detected a fault. Please consult an MG Authorised Repairer as soon as possible.
Airbag Fault	Indicates that the Airbag system has detected a fault. As soon as conditions permit, safely stop the vehicle and switch off the engine and contact an MG Authorised Repairer immediately.

Warning Message	Procedure
Front Left/Front Right/Rear Left/Rear Right Tyre Sensor Battery Low	Indicates that the Tyre Pressure Monitoring system has detected that a tyre pressure sensor has a low battery. Please consult an MG Authorised Repairer as soon as possible.
TPMS Fault	Indicates that the tyre pressure monitoring system has detected a fault. Please consult an MG Authorised Repairer as soon as possible.
12V Battery Charging System Fault	Indicates that the 12V battery charging system has failed. Please consult an MG Authorised Repairer immediately.
Rear Drive Assist System Fault	Indicates that the rear drive assist system (RDA) has detected a fault. Please consult an MG Authorised Repairer as soon as possible.

# Instruments and Controls

## Information Centre - Colour Display B \*

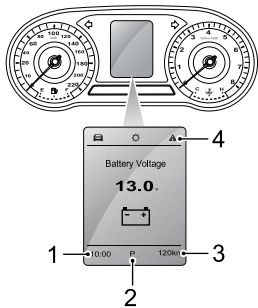

- 1 Digital Clock
- 2 Gear Display \*
- 3 Total Mileage
- 4 General Information

### Digital Clock

Displays the current time in digital form.

### Gear Display \*

Displays the current gear position of the auto transmission (P, R, N, D, S, 1, 2, 3, 4, 5, 6, 7\*, 8\*). If "EP" is displayed, it indicates that a fault has been detected with the transmission. Please seek an MG Authorised Repairer as soon as possible. Refer to "Starting & Driving" section.

### Total Mileage

Displays the total driving mileage of the vehicle.

### General Information

The general information function can be selected as follows:

- Press the UP/DOWN/LEFT/RIGHT button on the right hand multifunction steering wheel switch to shift the display items.
- Press the OK button on the right hand multifunction steering wheel switch to confirm or long press OK button to reset.
- Press the UP/DOWN button on the right hand multifunction steering wheel switch to make adjustment.

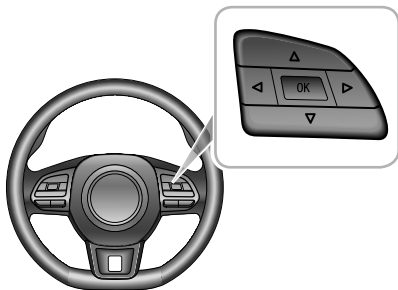

General information provides the following:

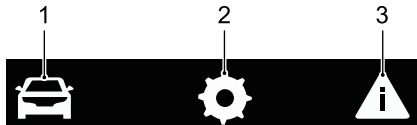

1 Trip Computer

2 Setting

### 3 Warning Information

#### *Trip Computer*

Trip computer functions contain the following:

- **Current Speed:** displays the current vehicle speed in a digital form.
- **Range to Empty:** displays the range that the vehicle can travel before the fuel tank is empty, the value of the range will change after refueling.
- **Current Journey:** displays the range, duration, average speed and average fuel consumption since startup. These values will be reset after a period of power off. It can also be reset by long pressing the OK button on the right hand multifunction steering wheel switch.
- **Accumulated Total:** displays the range, duration, average speed and average fuel consumption since the last reset. It can be reset by long pressing the OK button on the right hand multifunction steering wheel switch.
- **Instantaneous Fuel Economy:** displays the current fuel consumption when the engine is working.
- **Battery Voltage:** displays the 12V Battery Voltage.

# Instruments and Controls

---

- Tyre Pressures: displays the current tyre pressure data for each wheel.

## *Setting*

### **Brightness**

Displays the current level and allows adjustment of the backlight brightness.

**Note: This option can only be adjusted when the side lamps are on.**

### **Speed Warning** \*

Allows the setting of the over-speed alarm threshold.

### **Next Service**

Displays and facilitates the reset of the current vehicle maintenance information.

### **Warning Information**

Displays the warning information or important notes that are currently relevant to the vehicle.

### **Warning Message**

Warning messages and prompts are displayed in the information centre in the instrument pack. Any communications are displayed in 'pop up' messages, these can be divided into the following categories:

- Operating Instruction
- System State Instruction
- System Malfunction Alert

Please follow the instructions displayed in the 'pop up' message or in the case of a warning message, please refer to the relevant section of the owners manual to follow the correct instructions.

The following are a selection of warning messages that may appear in the information centre.



## Instruments and Controls

Warning Message	Procedure
Cruise Control Fault	Indicates that the cruise control system has detected a fault. Please consult an MG Authorised Repairer as soon as possible.
Engine Coolant Temperature High	High engine coolant temperature could result in severe damage. As soon as conditions permit, safely stop the vehicle and switch off the engine and contact an MG Authorised Repairer immediately.
Engine Coolant Temperature Sensor Fault	Indicates that the engine coolant temperature sensor has failed. As soon as conditions permit, safely stop the vehicle and switch off the engine and contact an MG Authorised Repairer immediately.

Warning Message	Procedure
Low Oil Pressure	Indicates that the oil pressure is too low, which may result in severe engine damage. As soon as safety permits, stop the car, switch off the engine and check the engine oil level. Contact an MG Authorised Repairer as soon as possible.
Engine Fault	Indicates that a failure has occurred that will effect engine performance and emissions. Contact an MG Authorised Repairer as soon as possible.
Check Engine	Indicates that a failure has occurred that may severely damage the engine. As soon as conditions permit, safely stop the vehicle, switch off the engine and contact an MG Authorised Repairer immediately.

## Instruments and Controls

Warning Message	Procedure
Clutch Switch Fault	Indicates that the clutch switch has detected a fault. Please consult an MG Authorised Repairer as soon as possible.
Ignition System Fault	Indicates that the ignition system has detected a fault. Please consult an MG Authorised Repairer immediately.
Start Stop Button Fault	Indicates that the Start Stop button has detected a fault. Please consult an MG Authorised Repairer immediately.
Passive Entry Fault	Indicates that the passive keyless entry (PKE) function has detected a fault. Please consult an MG Authorised Repairer as soon as possible.

Warning Message	Procedure
ABS Fault	Indicates that the anti-lock brake system (ABS) has failed and the ABS function is about to be disabled. Please consult an MG Authorised Repairer immediately.
Brake Fault	Indicates that the brake fluid could be low or a fault has been detected in the Electronic Brake-force Distribution (EBD) system. As soon as safety permits, stop the car, switch off the engine and check the brake fluid level. Contact an MG Authorised Repairer as soon as possible.
Stability Control Fault	Indicates that the stability control system has detected a fault. Please consult an MG Authorised Repairer immediately.

# Instruments and Controls

Warning Message	Procedure
Traction Control Fault	Indicates that the traction control system has detected a fault. Please consult an MG Authorised Repairer immediately.
EPB System Fault	Indicates that the electronic parking brake system (EPB) has detected a fault. Please consult an MG Authorised Repairer as soon as possible.
Park Brake Force Not Enough	Indicates that there is an issue with the electronic parking brake, it may not be able to provide adequate clamping force. Contact an MG Authorised Repairer as soon as possible.
Autohold Fault	Indicates that the Autohold System has detected a fault. Please consult an MG Authorised Repairer as soon as possible.

Warning Message	Procedure
Hill Descent Control Fault	Indicates that the hill descent control system has detected a fault. Please consult an MG Authorised Repairer as soon as possible.
EPS Performance Reduced	Indicates that the electric power steering system has a general failure and that the steering performance has been reduced. As soon as conditions permit, safely stop the vehicle and switch off the engine. After a short while, start the engine, drive the vehicle a short distance and monitor the operation of the steering, if the message is still displayed or the steering assistance reduced please contact an MG Authorised Repairer immediately.

## Instruments and Controls

Warning Message	Procedure
EPS Assistance Failure	Indicates that the electric power steering system has failed. Please consult an MG Authorised Repairer immediately.
Steering Angle Fault	Indicates that the steering angle sensor has failed. Please consult an MG Authorised Repairer as soon as possible.
Steering Angle Uncalibrated	Indicates that the steering angle sensor is not calibrated. Please consult an MG Authorised Repairer as soon as possible.
ESCL Fault	Indicates that a fault has been detected with the Electronic Steering Column Lock (ESCL). As soon as conditions permit, safely stop the vehicle and switch off the engine. Contact an MG Authorised Repairer as soon as possible.

Warning Message	Procedure
Fuel Sensor Fault	Indicates that fuel sensor has detected a fault. Please consult an MG Authorised Repairer as soon as possible.
Airbag Fault	Indicates that the Airbag system has detected a fault. As soon as conditions permit, safely stop the vehicle, switch off the engine and contact an MG Authorised Repairer immediately.
Airbag Lamp Fail	It indicates that the airbag lamp has failed. Please consult an MG Authorised Repairer as soon as possible.
Front Left/Front Right/Rear Left/Rear Right Tyre Sensor Battery Low	Indicates that the Tyre Pressure Monitoring system has detected that a tyre pressure sensor has a low battery. Please consult an MG Authorised Repairer as soon as possible.

## Instruments and Controls

---

1

Warning Message	Procedure
TPMS Fault	Indicates that the tyre pressure monitoring system has detected a fault. Please consult an MG Authorised Repairer as soon as possible.
12V Battery Charging System Fault	Indicates that the 12V battery charging system has failed. Please consult an MG Authorised Repairer immediately.

# Instruments and Controls

---

## Warning Lights and Indicators

Some warning lamps illuminate or flash accompanied by a warning tone.

### High Beam Indicator - Blue



The indicator illuminates when the headlamp high beam is turned on.

### Side Lamp Indicator - Green



The indicator illuminates when the side lamps are on.

On some models, if the side lamps are switched ON and the driver opens the door, this indicator will illuminate accompanied by an audible warning chime reminding the driver to switch the side lamps OFF.

### Rear Fog Lamp Indicator - Yellow



The indicator illuminates when the rear fog lamps are on.

### Front Fog Lamp Indicator - Green \*



The indicator illuminates when the front fog lamps are on.

### Direction Indicator Lamp - Green



The left and right direction indicator lamps are represented by directional arrows that are located at the top of the instrument pack. When the turning signal lamp flashes, the direction indicator lamp on the corresponding side also flashes. If the hazard warning lamps are operated, both direction indicator lamps will flash together. If either direction indicator lamp in the instrument pack flashes very rapidly, it indicates that the turning signal light on the corresponding side has failed.

**Note:** Failure of a side repeater lamp will have no effect on the flash frequency of direction indicator lamp.

## Anti-theft System Warning Lamp - Red



If no valid key is detected, this lamp illuminates red. Please use the correct key, or put the smart key at the bottom of the centre console cup holder. For specific location requirements, refer to “Alternative Starting Procedure” in “Starting & Driving” section.

If the remote key battery is low, this lamp will flash. Please replace the battery as soon as possible.

## Airbag Warning Lamp - Red



If this lamp illuminates, it indicates that there is a failure in the SRS or seat belt. Please seek an MG Authorised Repairer at the earliest opportunity. An SRS or seat belt fault may mean the components may not be deployed in the event of an accident.

## Seat Belt Unfastened Warning Lamp - Red



If this lamp illuminates or flashes, it indicates that the seat belt for the driver or front passenger\* remains unfastened.

## Cruise Control Indicator - Green/Yellow\*



If the cruise control function is enabled, the system will enter into the standby state and the indicator illuminates in yellow.

When the cruise control system operates, this indicator illuminates green, indicating the cruise control system is activated.

If a failure in the cruise control system is detected, the indicator will flash in yellow. Please contact an MG Authorised Repairer as soon as possible.

# Instruments and Controls

---

## Engine Malfunction Warning - Yellow



This lamp will illuminate if an engine fault occurs that will effect engine performance during driving. Please stop the car as soon as safety permits, switch the engine OFF and contact an MG Authorised Repairer immediately.

## Engine Emissions Malfunction Warning - Yellow



If an engine fault occurs that will effect engine performance and emission after starting the vehicle, this lamp will illuminate. Please contact an MG Authorised Repairer as soon as possible.

## Engine Coolant Temperature Warning - Red



When the engine coolant temperature warning lamp illuminates red, it indicates that the coolant temperature is high. If the engine coolant temperature continues to rise, the engine coolant temperature warning lamp will flash.

High engine coolant temperature could result in severe damage. Please stop the car as soon as safety permits, switch the engine OFF and contact an MG Authorised Repairer immediately.

## Low Oil Pressure Warning - Red



If this lamp illuminates after starting the vehicle, it indicates that the oil pressure is too low, which may result in severe engine damage. Please stop the car as soon as safety permits, switch the engine OFF and check oil level (refer to "Engine Oil Level Check and Top Up" under the "Maintenance"). Contact an MG Authorised Repairer immediately.

## Alternator Malfunction Warning - Red



If this lamp illuminates after starting the vehicle, it indicates that the 12v battery charging system has a failure. Please contact an MG Authorised Repairer immediately.



In cases of low battery power, the prompt messages will appear in the information centre. In this case, the system will limit or turn off some electrical devices, please start the vehicle to charge the battery.

## **Tyre Pressure Monitoring System (TPMS)**

### **Warning Lamp - Yellow**



If this lamp illuminates, it indicates a tyre pressure is low, please check the tyre pressures.

If this lamp flashes first and then remains on after a period of time, it indicates the system has a failure. Please contact an MG Authorised Repairer at the earliest opportunity.

## **Stability Control/Traction Control System**

### **Warning Lamp - Yellow**



If this lamp illuminates, it indicates that the stability control/traction control system has a failure. Please contact an MG Authorised Repairer immediately.

If this lamp flashes during driving, it indicates the system is operating to assist the driver.

## **Stability Control/Traction Control System Off**

### **Warning Lamp - Yellow**



This lamp will illuminate if the dynamic stability control/ traction control system is manually switched off.

## **ABS Malfunction Warning Lamp - Yellow**



This lamp illuminates to indicate an ABS fault. If an ABS failure occurs while driving, ABS will function abnormally, but normal braking will still be available. Please contact an MG Authorised Repairer as soon as possible.

## **Brake System Malfunction Indicator Lamp -**

### **Red**



If this lamp illuminates, it indicates a failure with the braking system such as brake fluid loss or electronic

# Instruments and Controls

---

brake force distribution failure. Please stop the car as soon as safety permits, switch the engine OFF and check brake fluid level (refer to "Brake Fluid Check and Top Up" under the "Maintenance" section). If the brake fluid level appears satisfactory contact an MG Authorised Repairer at the earliest opportunity.

For manual parking brake, the lamp illuminates when the parking brake is applied and extinguishes when it is fully released. If the parking brake is not released, when the vehicle speed exceeds 5 km/h, this warning lamp will flash. If the lamp remains on after the parking brake has been released, it indicates that there is a failure in the braking system. Please stop the car as soon as safety permits, switch the engine OFF and contact an MG Authorised Repairer immediately.

## **Electronic Parking Brake (EPB)/Automatic Parking Status Indicator Lamp - Red/Green \***



If this lamp illuminates red, it indicates the electronic parking brake is enabled or in the process of dynamic braking. When it flashes red, it indicates the

electronic parking brake has failed. Please contact the MG Authorised Repairer at the earliest opportunity.

When the auto hold system is operating to assist the driver, this lamp illuminates green.

## **Electronic Parking Brake (EPB) System Malfunction Indicator Lamp - Yellow \***



If an electronic parking brake system failure is detected or the system is under diagnosis, the indicator lamp will illuminate. Please contact an MG Authorised Repairer at the earliest opportunity.

## **Hill Descent Control (HDC) On/Malfunction Indicator Lamp - Green/Yellow**



Operating the HDC switch will activate the function, the system will enter the stand by mode and the warning lamp illuminates green, the lamp will extinguish when the system is turned off. If the vehicle is under the control of HDC the green warning lamp will flash.

If the HDC system detects a fault or fails, the warning lamp illuminates yellow. Please contact an MG Authorised Repairer immediately.

## **Electric Power Steering System (EPS)/ Electronic Steering Column Lock (ESCL)**

### **Warning Lamp - Yellow/Red \***



The warning lamp is used to indicate electric power assisted steering failure or electronic steering column lock failure.

When this lamp illuminates yellow, it indicates the electric power assisted steering system has a general failure and the performance is reduced. Please stop the car as soon as safety permits. If the lamp still illuminates after restarting the vehicle and driving for a short while, please contact an MG Authorised Repairer immediately.

When this lamp illuminates red, it indicates that the EPS has a failure relevant to the steering angle sensor. Please contact an MG Authorised Repairer at the earliest opportunity.

When this lamp illuminates red and flashes, it indicates the electric power assisted steering system has a severe failure and heavy steering. Please contact an MG Authorised Repairer immediately.

When the lamp illuminates yellow and flashes, it indicates the electric steering column lock \* has a failure. Please stop the car as soon as safety permits, switch the engine OFF and contact an MG Authorised Repairer immediately. If this lamp extinguishes after flashing for a while, it indicates that the steering wheel is locked, please attempt to rotate the steering wheel to remove any adverse loads.

### **Low Fuel Warning Lamp - Yellow**



The warning lamp illuminates yellow when the fuel remaining in the fuel tank is low. If possible, please refuel before the low fuel warning lamp illuminates.

When the fuel level continues to fall, this lamp flashes. When fuel is added to the tank and the fuel level rises above the alert limit, this lamp extinguishes. If it does not extinguish, please contact an MG Authorised Repairer for service as soon as possible.

# Instruments and Controls

---

**Note:** *When driving on steep or rough roads while the fuel level is low, the warning lamp may illuminate.*

## System Fault Messages Indicator - Yellow \*



This indicator is used to alert the driver to the fact that there is a warning stored in the vehicle IPK system. Please refer to "Information Centre" in this section for these failures.

## Active Speed Limit System Warning Lamp — Yellow \*



This warning lamp illuminates if an active speed limit system failure is detected. Please contact an MG Authorised Repairer as soon as possible.

## Active Speed Limit System Indicator — Red \*



When the active speed limit system is armed or active, if the target vehicle speed is currently set, this

indicator illuminates and displays the target vehicle speed value.

When the active speed limit system is working, if the current speed exceeds the set target speed, this indicator will flash, and the system will immediately reduce the speed to below the target speed. The active speed limiter only uses engine braking to reduce speed - it is not a substitute for physical brake application. If the vehicle needs to be slowed or stopped quickly the brake pedal **MUST** be applied.

## Lights and Switches

### Master Lighting Switch

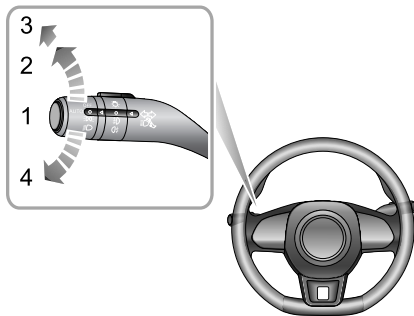

- 1 AUTO Lamp \*
- 2 Side Lamps and Switch Illumination
- 3 Dipped Headlamps
- 4 Lights OFF

### AUTO Lamp \*

When the START/STOP Switch is in the ACC position, the auto lighting system defaults to the ON position (1). The auto lighting system will automatically switch the side lamps and switch illumination on and off according to the intensity of current ambient light.

With the START/STOP Switch switched to the ON position, the auto lighting system defaults to the ON position (1). The auto lighting system will automatically switch the side lamps, switch illumination and dipped headlamps on and off according to the intensity of current ambient light.

### Side lamps and Switch Illumination

Turn the master lighting switch to position 2 to operate the side lamps and switch illumination. With the START/STOP Switch in the OFF position if the lighting switch is in position 2 and the driver's door opened an audible warning will sound to alert the driver, the side lamps will remain on.

# Instruments and Controls

---

## Dipped Headlamps

When the START/STOP Switch is in the ON position, turn the master lighting switch to position 3 to operate the dipped headlamps, side lamps and switch illumination.

## Lights Off

Turn the master lighting switch to position 4, this will switch off all lamps, releasing the switch will allow it to return to the AUTO switch position.

## Follow Me Home

After the START/STOP Switch is turned off, pull the lighting stalk switch towards the steering wheel. This will enable the Follow Me Home function, dipped beam headlamps and side lamps will illuminate depending upon the vehicle configuration. It can be set in the "Comfort and Convenience" in Vehicle Settings on the entertainment display.

## Daytime Running Lamp

The daytime running lamps turn on automatically when the START/STOP Switch is in the ON position. When

the side lamps are switched on, the daytime running lamps extinguish automatically.

## Find My Car

After the vehicle has been left in a locked condition for a few minutes pressing the lock button again on the remote key will enable the Find My Car function. This function will identify the car by means of an audible and visual alert. Pressing the Lock button on the handset again will suspend this operation. Pressing the Unlock button will cancel this operation. This feature can be set via "Comfort and Convenience" in the Vehicle Settings on the entertainment display.

# Instruments and Controls

## Headlamp Levelling Manual Adjustment

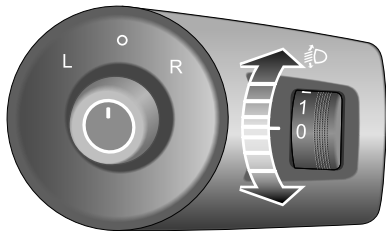

Position 0 is the initial position of the headlamp levelling adjustment switch. The headlamp levelling adjustment can be made as per the following table according to the vehicle load.

Location	Load
0	Driver, or driver & front passenger.
1	All the seats occupied with no load.
2	All the seats occupied plus an evenly distributed load in the boot, or driver with full load.
3	Driver only, plus an evenly distributed load in the boot.

# Instruments and Controls

---

## Fog Lamp Switch



*Fog lights should only be used when visibility is below 100m - other road users could be dazzled in clear conditions.*

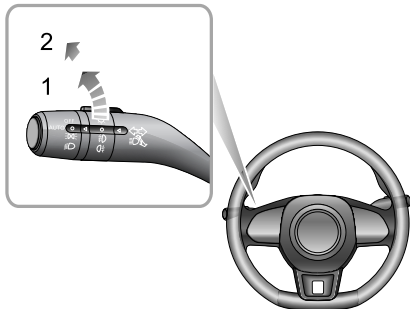

## Front Fog Lamps \*

With the START/STOP Switch in the ON position and the side lamps on, turn the fog lamp switch to position 1, this

will turn on the front fog lamps. The indicator illuminates in the instrument panel when the front fog lamps are on.

## Rear Fog Lamp

With the START/STOP Switch in the ON position and the headlamps or front fog lamps on, turn the fog lamp switch to position 2, this will turn on the rear fog lamp, release the switch to allow it to return to the last position. The indicator illuminates in the instrument panel when the rear fog lamp is on.



## Direction Indicator/Main Beam Switch



*Take care not to dazzle oncoming vehicles when driving using main beam headlamps.*

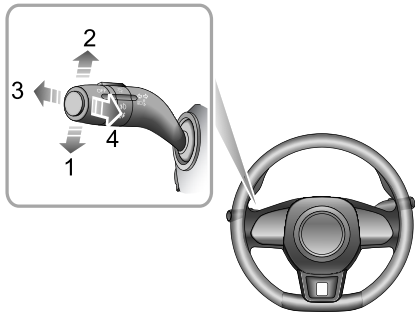

## Direction Indicators

Move the lever down to indicate a LEFT turn (1). Move the lever up to indicate a RIGHT turn (2). The corresponding

GREEN indicator lamp in the instrument pack will flash when the turning signal lamps are working.

Rotating the steering wheel will cancel the indicator operation (small movements of the steering wheel may not operate the self cancelling). To indicate a lane change, move the lever briefly and release, the indicators will flash three times and then cancel.

## Headlamp High/Low Beam Switching

With the START/STOP Switch in the ON position and the master lighting switch turned to position 3, or the auto function has switched the lights on, push the lever (3) towards the instrument panel to turn on headlamp high beams. The high beam indicator lamp in instrument pack illuminates, press the lever (3) again to switch to headlamp low beams.

## High Beam Flash

To briefly flash the high beam on and off, pull the lever towards the steering wheel (4) and then release.

## Auxiliary Lighting System \*

Adding front fog lamps on traditional headlamps, the auxiliary lighting system aims to illuminate the blind zone at the side when the car makes a turn. With this function, the driver can find other vehicles and obstacles in advance, so as to improve the driving safety to a large extent.

## Lighting Mode during Cornering

While the car is driving forward, the speed is lower than 40km/h, and the dipped beams are on, turn on the turn signal lamps or allow the steering wheel angle more than 45°, the system will automatically turn on the single side front fog lamp. Turn off the turn signal lamps or allow the steering wheel angle less than 10°, the system will exit from the lighting mode.

## Lighting Mode during Parking

While the car is reversing and the dipped beams are on, the system will automatically turn on the front fog lamps on both sides and the reverse lamp. When the vehicle speed is higher than 15km/h, or the reverse lamp is turned off for more than 10s, the system will exit from the lighting mode.

## Hazard Warning Lamp

Press the hazard warning lamp button  to turn on the hazard warning lamps. The turning signal lamps and direction indicator lamps will flash together. Press the button again to switch off the hazard warning lamps. All turning signal lamps and direction indicator lamps will stop flashing. For more details and location refer to 'Emergency Information' 'Hazard Warning Devices'.

## Wipers and Washers

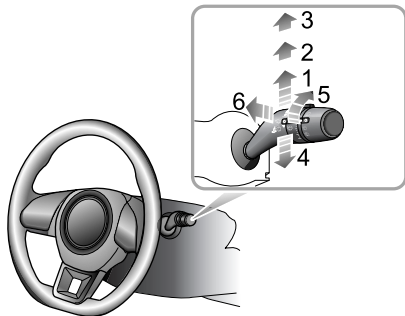

### Windscreen Wiper Operation

The wipers and washers will only operate with the START/STOP Switch in the ACC/ON/RUNNING position.

Operate the lever to select different wipe speeds:

- Intermittent wipe (1)
- Slow wipe (2)
- Fast wipe (3)

- Single wipe (4)
- Automatic wipe interval adjustment \* / Rain sensor sensitivity adjustment \*(5)
- Programmed wash/wipe (6)

### Intermittent Wipe

By pushing the lever up to the Intermittent wipe position (1), the wipers will operate automatically. Turn the switch (5) \* to adjust the intermittent wipe frequency. This speed will also change with the vehicle speed. As the vehicle speed increases, the wiper frequency increases. As the vehicle speed decreases, the wiper frequency decreases.

Some models are equipped with a rain sensor fitted to the interior rear view mirror base to detect varying amounts of water on the outside of the windscreen. With automatic wipe, the vehicle will adjust the wiping speed according to the signals provided by rain sensor. Turn the switch (5) to adjust the sensitivity of rain sensor. As the sensitivity increases, the wiping interval decreases.

**Note: Immediately operating the wiper one time can be achieved by increasing the sensitivity of rain sensor. If the rain sensor detects a continuous rainwater, the**

# Instruments and Controls

*wiper will keep working. When no rain is detected, it is recommended to switch off automatic wipe.*

## Slow Wipe

By pushing the lever up to the slow wipe position (2), the wipers will operate slowly. Move the lever to re-select the wipe speed.

## Fast Wipe

By pushing the lever up to the fast wipe position (3), the wipers will operate fast. Move the lever to re-select the wipe speed.

## Single Wipe

Pressing the lever (4) down and releasing will operate a single wipe, if the lever is held down, the wipers will operate until the lever is released.

**Note:** *When the car is stationary, if the bonnet is opened, the front wiper/washer will stop work immediately for some models.*

### IMPORTANT

- Avoid operating the wiper on a dry windscreen.
- In freezing or extremely hot weather conditions, make sure that the wiper blades are not frozen/adhered to the windscreen.
- In winter, remove snow or ice from around the arms and blades, including the wiped area of the screen.

## Programmed Wash/Wipe

Pulling the lever toward the steering wheel (6) will operate the windscreen washers. After a short delay, the wipers will commence operating in conjunction with the washers.

**Note:** *The wipers continue operating for a further three wipes after the lever is released. After several seconds, there will be a further wipe to remove any fluid draining down the screen.*

# Instruments and Controls

## IMPORTANT

If the washers fail to deliver the screen wash solution (dirt or ice may have blocked the jets), release the lever immediately. This will prevent the wipers from operating, and the consequent risk of visibility being impaired by dirt smearing across the unwashed windscreen.

## Rear Window Wiper Operation

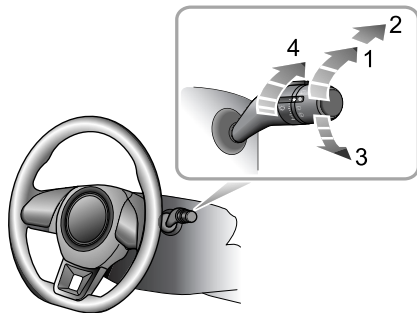

- Intermittent wipe (1)
- Wash and wipe (2)
- Wash and wipe (3)
- Intermittent wipe frequency adjustment (4)

The rear window wiper and washer will only operate with the START/STOP Switch in the ACC/ON/RUNNING position. Turn the rear window wiper switch to intermittent wipe (1), the rear window wiper will operate,

## Instruments and Controls

---

after 3 consecutive wipes, the wipers will enter into intermittent mode. The time period between the wipes can be increased/decreased via the intermittent wipe frequency adjustment switch (4).

Turn the rear window wiper switch to wash and wipe (2) position and hold, the rear window wiper and washer will operate, the rear window wiper wipes quickly. release the switch allowing it to return to intermittent wipe (1), the rear window washer will stop operating, and the wiper wipes slowly, change the stalk switch position 4 to adjust the wipe speed.

Turn the rear window wiper switch to wash and wipe (3) and hold, the rear window wiper and washer will operate. release the switch allowing it to return to OFF position, the rear window washer will stop operating, and the rear window wiper wipes for 3 times, after several seconds, the wiper will wipe once more to remove the washer fluid on the windscreen.

**Note: When the tailgate is opened, rear window wiper operations will be disabled.**

**Note: When the windscreen wipers are switched on, if the shift control lever is moved to, or in the R position, the rear window wiper will operate.**

## Steering System

### Adjustment of Steering Column



***DO NOT attempt to adjust the angle of the steering column while the vehicle is in motion. This is extremely dangerous.***

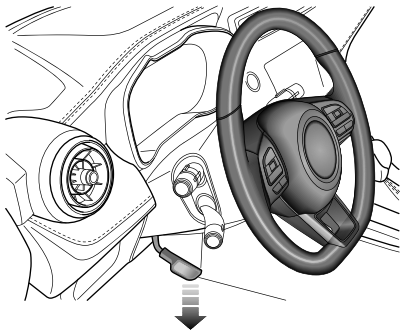

To adjust the angle of the steering column to suit your driving position:

- 1 Fully release the locking lever.
- 2 Hold the steering wheel in both hands and tilt the steering column up or down to move the wheel into the most comfortable position.
- 3 Once a comfortable driving position has been selected, pull the locking lever fully up to lock the steering column into its new position.

## Electric Power Steering



***If the electric power steering fails or cannot operate the steering will appear very heavy, this will affect driving safety.***

The electric power steering system only works when the vehicle is started. The system operates via a motor with assistance levels automatically adjusted based on vehicle speed, steering wheel torque and steering wheel angle.

### IMPORTANT

Holding the steering wheel on full lock for long periods will result in a reduction in power assistance causing a heavier feel to the steering for a short period of time.

## Steering Mode Switching

The electric power steering system provides 3 different steering modes:

- 1 Normal: provides moderate power assistance.
- 2 Urban: provides a high level of assistance, with a light feel.
- 3 Dynamic: provides low level power assistance, with a heavier feel.

The steering mode is selectable for vehicle speeds up to 60 mph (100 km/h) through the touch screen interface.

***Note: Steering mode selection is only available when the steering wheel is not being turned. Any changes made in this state will not take effect until the steering wheel is straight ahead.***

## Electric Power Steering (EPS) Warning Lamp

See "Warning Lamps and Indicators" under the "Instruments and Controls" section.



### Horn



Press the horn button area on the steering wheel (as indicated by the arrow) to operate the horn.

**Note:** *The vehicle horn switch location and the driver's airbag are located in close proximity on the steering wheel. The illustration shows the position of the horn switches, please ensure that you press in this area to*

*avoid any potential conflict with the operation of the airbag.*

#### IMPORTANT

To avoid possible SRS issues, please do not press with excessive force or hit the airbag cover when operating the horn.

# Instruments and Controls

## Mirrors

### Door Mirrors

**Note:** Objects viewed in door mirrors may appear further away than they actually are.

### Electric Door Mirror Glass Adjustment

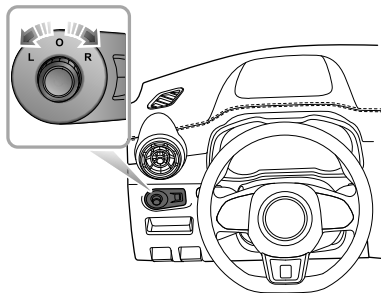

- Rotate the knob to select left (L) or right (R) rearview mirror.

- Move the knob in the desired direction to adjust the angle of the exterior mirror glass.
- Upon completion of the adjustment, rotate the knob back to the central position, this will ensure no accidental adjustment of the mirror.

### Heating Elements \*

The door mirrors have integral heating elements which disperse ice or mist from the glass. The heating elements operate while the Heated Rear Window  is switched on.

**Note:** The heating elements of rear window and mirror will only work when the power system is running.

### Mirror Folding

The mirrors can be folded back towards the side windows into a 'park' position to enable the car to negotiate narrow openings and avoid collisions.

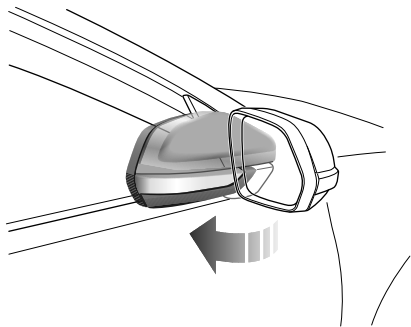

### ***Manual Folding of Door Mirror \****

For vehicles not fitted with the electric door mirror fold option, the exterior mirrors can only be folded backwards manually.

### ***Electric Folding of Door Mirror \****

For vehicles fitted with electric door mirror folding, rotate the knob to the middle position, and push the knob down. The door mirrors will be folded automatically. Pushing

the knob downwards again will return the mirrors to their original position.

Operating the key fob lock/unlock buttons will fold/unfold the door mirrors.

**Note:** *Electrical folding door mirrors that have been moved from their positions by manual or accidental means must be reset by operating the knob to complete fold and deployment one time.*

#### IMPORTANT

- Door mirror glass adjustments and door mirror folding are operated by electrical motors. Operating them directly by hand may damage the internal components.
- Washing or flushing door mirrors with high pressure water jets or car washes may result in electrical motor failure.

### Interior Rearview Mirror

Adjust the body of the interior rearview mirror to achieve the best possible view. The anti-dazzle function of the interior rearview mirror helps to reduce glare from the headlamps of following vehicles at night.

### Manual Anti-dazzle Interior Rearview Mirror

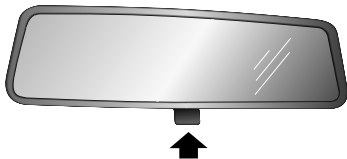

Move the lever at the base of the mirror forward to 'dip' the mirror and achieve the anti-dazzle function. Normal visibility is restored by pulling the lever back again.

**Note:** *In some circumstances, the view reflected in a 'dipped' manual mirror can confuse the driver as to the precise location of following vehicles.*

## Sunvisors



*The vanity mirror on the driver side should only be used when the car is stationary.*

Sunvisors (1) are arranged on the roof ahead of both the driver and the front passenger. Some models have vanity mirror (2), depending on the vehicle configuration. For the models which have vanity mirror, pull the sunvisor downward and slide the cover aside to use the vanity mirror.

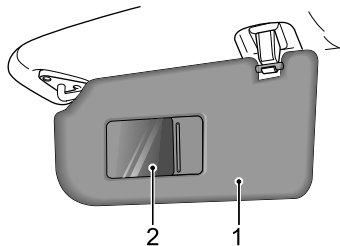

## Windows

### Power Operated Window Switch

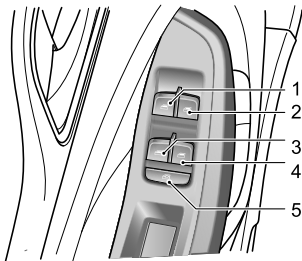

- 1 Front Left Window Switch
- 2 Front Right Window Switch
- 3 Rear Left Window Switch
- 4 Rear Right Window Switch
- 5 Rear Window Isolation Switch

### Window Operation



*When the window is up or down, ensure the safety of the personnel in the vehicle, especially the children, to prevent being pinched by the window.*

Push the switch (1-4) down to lower, and pull the switch up to raise the window. The window will stop moving as soon as the switch is released (unless the 'One-Touch' function is active).

**Note:** *The front and rear passenger windows can also be operated by individual window switches, mounted on each door. The rear window switches will not be operated if the rear window isolation switch has been activated.*

**Note:** *The electric window can be operated with the vehicle power system in the ACC, ON and RUNNING positions. (For safety: doors should be closed).*

## Rear Window Isolation Switch

Press the button (5) to isolate the rear window controls, press again to restore control.

**Note:** *It is recommended that you ISOLATE the rear window switches when carrying a child.*

## “One-Touch” Down

The driver's window control switch (1) has 2 positions. Short press the window control switch to the "2" position and release. The window automatically descends to fully open. Window movement can be stopped at desired position at any time by briefly operating the switch again.

## “One Touch” Up with “Anti-Trap” \*

The driver's window control switch (1) has the “one-touch” up function. Lifting the switch to the "2" position for a short time and releasing will automatically close the window completely. Window movement can be stopped at a desired position at any time by briefly operating the switch again.

The “Anti-Trap” function is a safety feature which prevents the window from fully closing if an obstruction is sensed -

if this happens the window will open slightly to allow the obstruction to be removed.

**Note:** *DO NOT operate the power window controls continuously several times in a short time frame, otherwise the power window controls may be disabled to protect the motor. If this occurs, please wait a few seconds until the motor cools down. Do not disconnect the negative battery cable while waiting for the motor to cool down.*

**Note:** *If the battery is cut off during lifting and lowering of the window, One Touch Up and Anti-Trap mode may be not operational, in this case, raise the window to the upmost position by lifting up the switch briefly and consecutively; lifting up the switch for about 5 seconds, One Touch Up and Anti-Trap mode will be resumed.*

# Instruments and Controls

---

## Sunroof\*

The sunroof consists of two glass panels, only the front section can be opened by sliding or tilting. The sunshade can be opened or closed as a complete unit.

### Instructions



***DO NOT allow passengers to lean out of an open sunroof whilst the vehicle is in motion. Injuries may occur from objects such as tree branches.***



***Safety of the vehicle occupants must be observed at all times. DO NOT allow limbs to be placed in the moving path of the sunroof at any time, injury may occur.***

- Avoid fully opening the sunroof during rain showers.
- It is advised not to open the sunroof when the car speed exceeds 120 km/h.
- Where possible, please clean off any residual water or raindrops off the sunroof prior to opening. Failure to do so may result in water entering the car.

- DO NOT use abrasive materials to clean the sunroof glass. Use only propriety glass cleaner or alcohol based solvent.
- DO NOT hold the operating switch in the open/close position for any length of time after operation is complete, this could damage the electrical components.
- Clean the sunroof regularly to maintain operation and performance. Visit an MG Authorised Repairer for service as required.



## Sunroof Operation

The sunroof will operate when the vehicle power system is in the ACC or ON/RUNNING modes.

## Sunroof Glass Operation

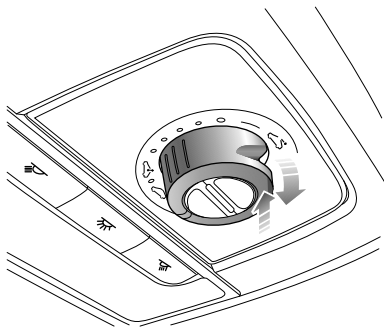

### *Opening the Sunroof Glass using Tilt*

With the sunroof glass fully closed, press the rear part of the switch in the direction of the arrow as indicated

in the graphic to fully 'tilt' the glass to the open position. Operation can be interrupted at the desired point by pressing the switch again.

### *Closing the Sunroof Glass from Tilt*

Pull down the rear of the switch to automatically close the sunroof in the direction as indicated by the arrow. Briefly pull down on the switch again will interrupt the operation at the desired position.

To manually close the sunroof, pull down the rear of the switch in the direction as indicated by the arrow and hold, until the sunroof reaches the desired position.

### *Opening the Sunroof Glass by Sliding*



Rotate the switch completely clockwise and hold until the sunroof slides fully open. To partially open the sunroof, place the switch in the required range position.

### *Closing the Sunroof Glass by Sliding*

## Instruments and Controls



Rotate the switch completely counterclockwise, the sunroof will slide fully closed. To partially close the sunroof, place the switch in the required range position.

### Sunroof Sunshade Operation

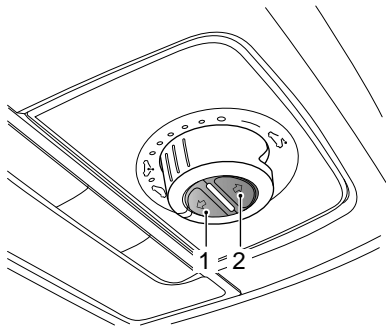

*Opening the sunshade.*

Short press the button (2) to automatically open the sunshade to its full extent. Short press the button at any time to cancel the request and stop the sunshade at that position.

To manually open the sunshade, press and hold the button until the sunshade reaches the desired position, then release it.

### *Closing the Sunshade*

Short press the button (1) to automatically close the sunshade completely. Short press the button at any time to cancel the request and stop the sunshade at that position.

To manually close the sunshade, press and hold the button until the sunshade reaches the desired position, and release it.

**Note:** *If the vehicle is to be parked in direct sunlight for a length of time it is recommended that the sunshade be closed to protect the interior trim components from damage, and to help regulate the in car temperatures.*

## Anti-pinch Function

The sunroof and sunshade feature an “Anti-Pinch” function, this is a safety feature which prevents the sunroof or sunshade from fully closing whilst in the automatic mode if an obstruction is sensed - if this happens the sunroof/sunshade will open slightly to allow the obstruction to be removed.

### *Forcibly Closing the Sunroof (over-riding the anti pinch)*

To forcibly close the sunroof glass after an anti-pinch intervention, gently pull the rear of the switch downwards within 5 seconds and hold in position until the sunroof glass is fully closed.

**Note: The anti pinch function is suspended during this operation.**

### *Forcibly Closing the Sunshade (over-riding the anti pinch)*

To forcibly close the sunshade after an anti-pinch intervention, press the close button within 5 seconds and hold it until the sunshade is fully closed.

**Note: The anti pinch function is suspended during this operation.**

**Note: The anti-pinch function only works when closing the sunroof during the slide operation.**

## Sunroof Initialisation

In the event of a power failure or battery disconnection when the sunroof glass or sunshade is in motion, the sunroof/sunshade will require initialisation when the power is restored.

To carry out the sunroof glass initialisation operation:

Fully close the glass - gently pull the rear of the switch downward and hold in position for 10 seconds, the sunroof will open a preset amount and stop, it will then close automatically- the sunroof glass is then initialised. During the whole process, the switch must remain in the pulled down position.

To carry out the sunshade initialisation operation:

Fully close the sunshade - press the close switch and hold in position for 10 seconds, the sunshade will open a preset amount and stop, it will then close automatically- the

## Instruments and Controls

---

sunshade is then initialised. During the whole process, the switch must remain pressed.

## Interior Lights

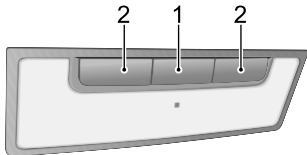

Press any one of buttons (2) to switch on the corresponding lamp, and press it again to switch the lamp off.

### Automatic Operation

Press the interior lights switch button (1) to turn on automatic operation, and press it again to turn off the function.

Interior light illumination occurs automatically whenever the following occur:

- The car is unlocked.
- Any door or the tailgate is opened.

- The vehicle power system is switched off, providing the sidelights have been illuminated during the previous 30 seconds.

**Note:** *If a door or the tailgate is open for more than 15 minutes, the front interior lamp will be switched off automatically to avoid battery drain.*

# Instruments and Controls

## Power Socket



*Please ensure the socket blanking plug is inserted when the power socket is not in use. This will ensure no debris or foreign objects enter the socket preventing its use or cause short circuits.*



*The 12V power socket has a voltage rating of 12V, and the maximum power of 120 Watt, please DO NOT use any electrical appliance that exceeds this rating.*



*Extended use of the accessory power socket and USB socket when the engine is switched off will cause premature discharging of the vehicle battery.*

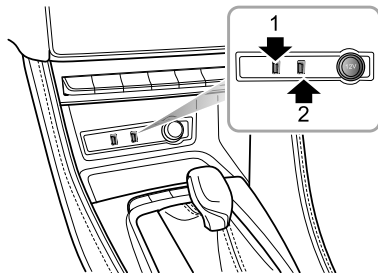

The 12V power socket is located under the shift control knob assembly in the centre console. It can be used as a power supply when the START/STOP Switch is in the ACC or ON/RUNNING positions when the blanking plug is removed.

Located to the left of the power socket are two USB ports. Both of them can be used to provide a 5V power supply or a data transmission connection.

## Instruments and Controls

---

1

**Note:** *The vehicle is not supplied with a cigar lighter. If required please contact your local MG Authorised Repairer.*

**Note:** *Due to differences in configuration the charging function of the USB port will be slower.*

There are two USB ports located at the rear of the centre console, these provide 5V voltage when serving as the power outlet.

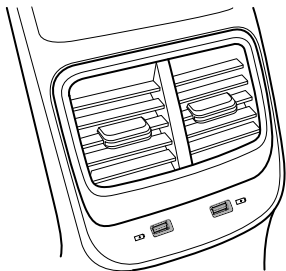

There is also one USB port located in the rear view mirror mounting trim cover, this provides a 5V power source.

# Instruments and Controls

---

## Storage Devices

### Instructions

- Please close all storage devices when the vehicle is in motion. Leaving these storage devices open may cause personal injury in cases of a sudden start-off, emergency braking and a car accident..
- Do not place flammable materials such as liquid or lighters in any storage devices. The heat in hot conditions may ignite flammable materials and lead to a fire.

## Glove Box

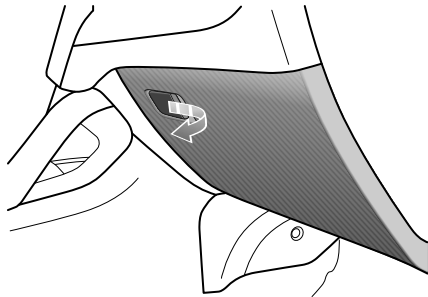

To open the glove box, pull the handle on the glove box cover (as indicated by the arrow).

Push the box cover forward to close the glove box. Make sure the glove box is fully closed when the vehicle is in motion.



# Instruments and Controls

## Card Box

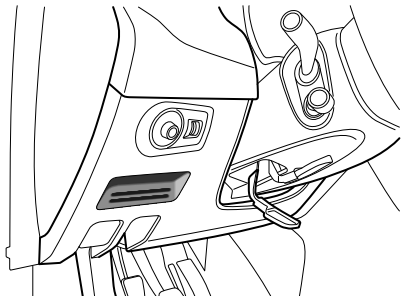

Located in the driver side lower dash trim panel.

## Centre Console Armrest Box

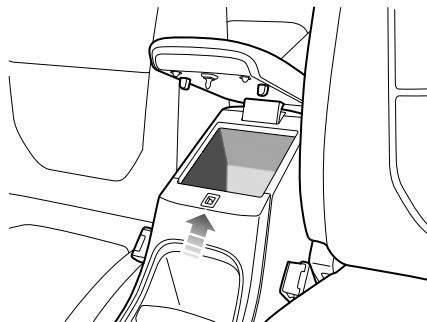

Lift the armrest (arrowed) to open the compartment cover. Put the cover down to close it.

## Glasses Box \*



*The glasses storage box should only be opened whilst the vehicle is stationary.*

# Instruments and Controls

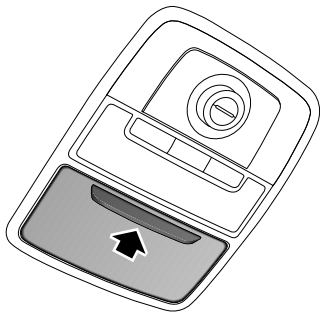

The glasses box is part of the front interior lam pack. To operate, press the panel (as indicated by the arrow), places glasses in the box. Press to close. Always close the glasses box when not in use.

**Note:** *Not all types/brands of glasses will fit in the box.*

## Loadspace



**DO NOT** place articles on the rear parcel shelf, they could move causing personal injury in the event of an accident, emergency braking or hard acceleration.

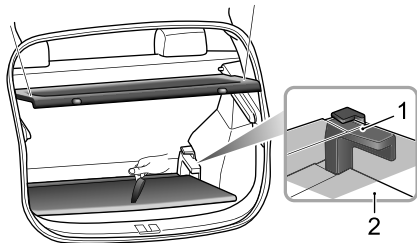

The rear parcel shelf is connected to the tailgate using straps and hooks. When opening the tailgate, the shelf will automatically be raised.

The spare wheel/tyre repair kit and tool kit are stowed beneath the loadspace carpet, lift the carpet for access. Always refit the carpet after use.

In addition, The loadspace carpet height can be adjusted by using the carpet bracket (figure 1, 2).

# Instruments and Controls

---

## Cup Holder



*Do not place hot drinks in the cup holder whilst driving. Spillage may result in personal injury or damage.*

## Centre Console Cup Holder (EPB)

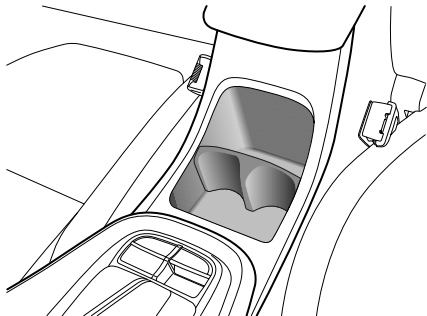

The centre console cup holder is situated at the front end of the centre console armrest assembly.

## Centre Console Cup Holder (IPB)

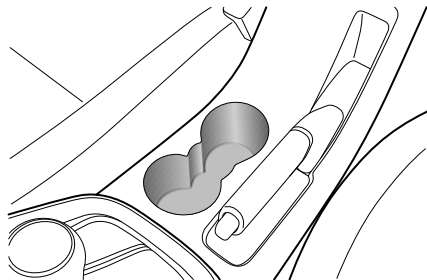

The centre console cup holder is situated at the front end of the centre console armrest assembly.

## Roof Luggage Rack \*



**Roof loads MUST NOT exceed the maximum authorised load. This may lead to injury or vehicle damage.**



**Loose or improperly fixed loads may fall from the roof luggage rack and lead to an accident or cause people injury.**



**When heavy or large items are carried on the roof luggage rack it may lead to changes in steering, handling and braking characteristics. Please avoid sharp manoeuvres, heavy braking and excessive acceleration.**

Pay attention to the following in using the roof luggage rack:

- Secure loads toward the front of the roof as far as possible. distribute loads evenly.
- DO NOT use automatic car washes with loads on the roof luggage rack.

- The overall height of the car is different when loads are fitted to the roof luggage rack. Please ensure there is adequate clearance when entering tunnels and garages.
- Ensure the loads carried by the roof luggage rack do not impede operation of the sunroof, roof antenna of tailgate opening.
- When installing or removing a piece of loading equipment, follow the instructions provided by the manufacturer of the loading equipment.

### Maximum Authorised Load for the Roof

The maximum authorised load for the roof is 75 kg, this includes the weight of the roof loads and that of the loading equipment installed.

Ensure you are aware of the weight of loads, and weigh them when necessary. Never exceed the maximum authorised load for the roof.

### Periodical Check

Always check the condition of the bolt connectors and fastenings before use. Periodically check the bolt connectors and fastenings for security.



## ***Air Conditioning and Audio Systems***

---

*70 Ventilation*

*73 Electronic Temperature Control*

*79 Entertainment Player \**

# Air Conditioning and Audio Systems

---

## Ventilation

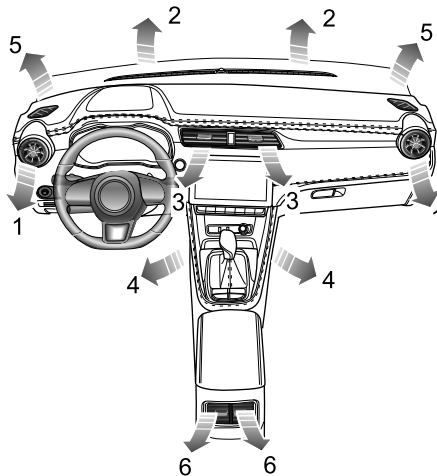

- 1 Side Vents
- 2 Windscreen/Defrost Vents
- 3 Centre Vent
- 4 Front Footwell Vents
- 5 Front Side Window Vents
- 6 Centre Console Vents \*



# Air Conditioning and Audio Systems

The heating, ventilation and air conditioning system provides fresh, cooling or heated air to the interior of the car. Fresh air is drawn in through the air intake grille under the front windscreen and the air conditioning filter.

Always keep the air intake grille clear of obstructions such as leaves, snow or ice.

## A/C Particle/Pollen Filter

Air conditioning filter element helps to prevent pollen and dust from entering the vehicle; PM2.5 filter element can not only prevent pollen and dust from entering the vehicle, but also effectively filter PM2.5 to keep the air in the vehicle fresh. In order to maintain the best filtering effect of the air conditioning filter element, please replace it within the specified maintenance interval.

## Vents

### Centre Vents

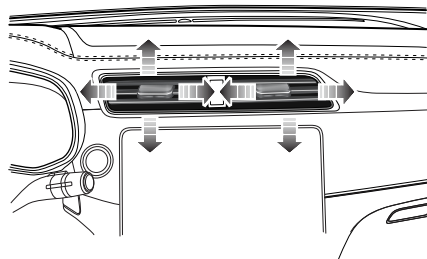

Slide the button in the centre of the louvres completely to the left or right to open or close the vent, adjust this button to direct the flow of air.

Toggle the button at the centre of each vent up and down, left and right to regulate the air direction.

# Air Conditioning and Audio Systems

---

## Side Vents

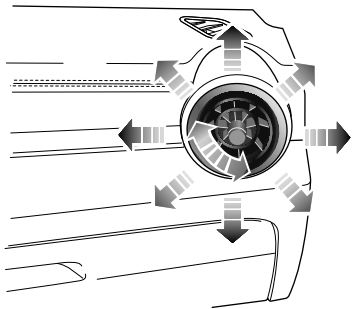

Rotate the centre thumb-wheel clockwise or anti-clockwise to open or close the vent. Toggle the centre thumb-wheel up, down, left or right to adjust the air direction.

## Centre Console Vents\*

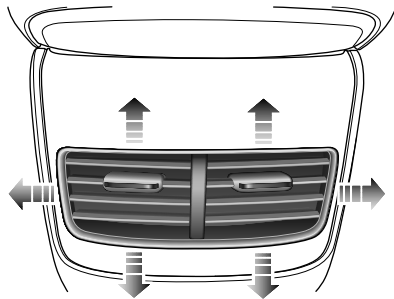

Slide the button in the centre of the louvres completely to the left or right to open or close the vent, adjust this button to direct the flow of air.

Toggle the button at the centre of each vent up and down, left and right to regulate the air direction.

# Air Conditioning and Audio Systems

## Electronic Temperature Control

### Infotainment Screen Control Interface

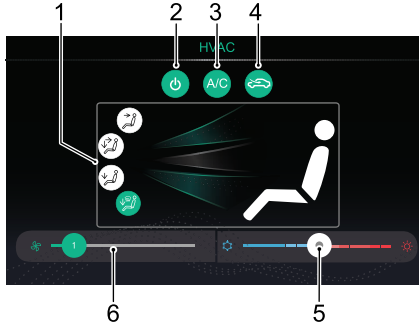

- 1 Air Distribution Mode
- 2 System On/Off
- 3 A/C Cooling On/Off
- 4 Air Recirculation Mode
- 5 Temperature Control
- 6 Blower Speed Control

# Air Conditioning and Audio Systems

---

## System On/Off

Touch the System On/Off Button on the control interface to switch the system on, all functions will revert to the state before shutdown. Touch again to switch off.

**Note:** *Turning off the infotainment screen will not affect the operation of the system*

## A/C Cooling On/Off

Touch the A/C Cooling On/Off Touch Button to turn the A/C cooling function ON/OFF.

**Note:**

- 1 The cooling/heating mode of the air conditioning will only operate when the engine is running.*
- 2 The heating/ventilation function is still available, when the A/C cooling is switched off.*
- 3 A small amount of water may remain in the air conditioner after usage, this may produce a peculiar smell. If this is a particular issue, it is recommended to switch off the cooling function and run the blower for a while with the engine running prior to switching off.*

## Air Recirculation Mode

Touch the recirculation button on the control interface to operate the air recirculation function, the image displayed in the switch will change to display your chosen position (external or internal circulation), if the air intake is closed the air inside the car is recirculated, preventing the entry of traffic fumes.









Recirculation mode is automatically activated when the screenwashers are used or reversing.

**Note:** *Leaving the system in recirculation mode can cause the windscreen to mist. If this happens, switch off recirculation and turn the controls to maximum demisting.*

## Air Distribution Mode

Select the corresponding Air Distribution Mode Touch Button as required to regulate the air distribution mode.

# Air Conditioning and Audio Systems

Touch Button	Icons on Interface	Air Distribution Mode
		To 'face'
		To 'face' and 'feet'
		To 'feet'
		To 'feet' + 'windscreen'

To 'face'. Directs air to the side, centre and centre console vents.

To 'face' and 'feet'. Directs air to the footwell, side, centre and centre console vents.

To 'feet'. Directs air to the footwell vents.

**Note:** In this mode, a small amount of airflow will be directed to the side, front side window and windscreen/defrost Vents.

To 'feet' + 'windscreen'. Directs air to the footwell, windscreen/defrost and front side window vents.

**Note:** In this mode, a small amount of airflow will be directed to the side vents.

## Blower Speed Control

Slide the blower speed segments left or right to regulate the blower speed, the lowest position is 1.

Touch the blower speed segment to quickly set the required blower speed.

## Temperature Control

Slide the temperature segment left or right to regulate the temperature of the air supplied by the vents.

Touch the temperature segment to quickly set the required temperature.

# Air Conditioning and Audio Systems

---

## Control Panel

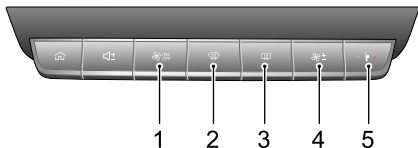

- 1 A/C Control Shortcut
- 2 Defrost/Demist Button
- 3 Heated Rear Window Button
- 4 Blower Speed Control Button
- 5 Temperature Control Button

## A/C Control Shortcut



Short press the A/C control shortcut to display the air conditioning interface on the infotainment screen.

Long press the A/C control shortcut to switch the system on, all functions will revert to the state before shutdown. Long press again to switch off.

## Blower Speed Control Button



Press the blower speed control button upward or downward to regulate the blower speed.

## Temperature Control Button



Press the temperature control button upward or downward to regulate the temperature of the air supplied by the vents.

## Defrost/Demist



Press Defrost/Demist Button on the control panel, the indicators on the button and display illuminate, the A/C cooling and external circulation functions are switched on, and the system enters the most effective warm or cold air setting to clear the windshield and side window.

Pressing the Defrost/Demist Button or the touch button on the display again will exit the defrost/demist state, the indicator goes out, and the system will return to the previous state.

In the defrost/demist mode, operation of the A/C cooling on/off button will switch the compressor on or off; operation of the air circulation mode button will switch between internal circulation and external circulation, without affecting the defrost/demist mode in either case; operation of other air distribution modes will switch to a corresponding air distribution mode and quit the defrost/demist mode.

**Note:** When the defrost/demist function is switched on below a preset temperature, the heated rear

window function will automatically operate, the Defrost/Demist button and the heated rear window button indicator lights will illuminate simultaneously.

## Heated Rear Window



**The heating elements on the inside of the rear window are easily damaged. DO NOT scrape or scratch the inside of the glass. DO NOT stick labels over the heating elements.**



Press this button on the control panel to operate the heated rear window function, the indicator in the switch will illuminate. The heated rear window function will automatically turn off after operating for 15 minutes. If the switch is pressed again within 5 minutes, the heated rear window will operate and then remain on for a further 8 minutes. Pressing the switch whilst the heated rear window is on will switch off the function and extinguish the indicator in the switch.

**Note:** The heated rear window will only operate when the engine is running.







# Air Conditioning and Audio Systems

---

**Note:** Heated door mirrors only operate when the heated rear window is activated.

## A/C Display



- 1 Temperature Status
- 2 A/C Cooling Status
- 3 Blower Speed/Air Distribution Mode Status :
  -  For 'face'
  -  For 'face' and 'feet'
  -  For 'feet'
  -  For 'feet' and 'windscreen'
  -  For 'windscreen'
- 4 Air Recirculation Mode Status :
  -  Internal circulation
  -  External circulation



## Entertainment Player \*

### Important Safety Information

- Do not attempt to fit, repair or modify the entertainment system by yourself, because there are high-voltage components in the device, which may cause electric shock. For internal inspection, adjustment or repair, please consult a local MG Authorised Repairer.
  - Do not allow this entertainment system to come into contact with liquids. If liquids or foreign objects enter into this entertainment system, please park your vehicle at a safe place, immediately switch off the ignition and contact a local MG Authorised Repairer. Do not use the entertainment system in this condition because doing so may result in a fire, electric shock, or other failure.
  - If you notice smoke, abnormal noises or odours from the entertainment system, or any other abnormal signs on the screen, switch the ignition off immediately and contact a local MG Authorised Repairer for service. Using this entertainment system in this condition may result in permanent damage to the system.
- Operation of video functions of the system is prohibited whilst the vehicle is in motion. MG Motor accepts no responsibility for any consequences caused by this operation. Please park your vehicle in a safe location select Park/Neutral, and apply the parking brake before making the necessary adjustments or watching "Video".
  - Particularly high or particularly low temperatures will interfere with normal operation. If the vehicle is not used and parked in direct sun or in a cold location for a long time, the car may become particularly hot or cold, in this environment the system may not work properly. Once the temperature inside the car is back to normal, the system will resume normal function. If it does not resume, please contact an MG Authorised Repairer for assistance.
  - Switch off entertainment system during refuelling.
  - Excessive use of the entertainment system without the vehicle being driven or engine running can drain the vehicle low voltage battery.
  - When using a mobile phone, keep the antenna of the mobile phone away from the screen to prevent the disruption of video signal in the form of spots, colored stripes, etc. on the screen.

# Air Conditioning and Audio Systems

---

## Cautions for Using Screen

- To protect the screen against damage, always touch panel keys with your finger. A touch pen may be used for special calibration.
- Please take care to protect the screen against direct sunlight. Extended exposure to direct sunlight will result in screen malfunction due to high temperature.
- When the temperature is beyond the operating temperature range (-30°C to +85°C), please do not use the screen, because the screen may not operate normally and could be damaged.
- Do not use excessive force to drag and drop or press the screen, damage or scratching may occur.
- To remove dust from the screen or clean the screen, power off the system first, then wipe the screen with a dry soft cloth. When wiping the screen, take care not to scratch the surface. Do not use irritative or abrasive chemical cleaners.

## Basic Operations

### Control Panel



1  (HOME) Button

Short press to return to the main interface.

2 Volume Adjusting Button

# Air Conditioning and Audio Systems

## Main System Interface



### 1 Radio/Music

Touch to enter the Radio/Music interface.

### 2 Car

Touch to enter the Vehicle Settings interface.

### 3 HVAC

Touch to enter the AC interface.

### 4 Others

Touch or or swipe left or right at the bottom of the screen to view the following functions.

- Phone

Touch to enter the Bluetooth Phone interface.

- Pictures

Touch to enter the Pictures interface.

- Set up

Touch to enter the Settings interface.

- 360 View \*

Touch to enter the 360 View interface.

- Apple CarPlay \*

Touch to enter the Apple CarPlay interface.

- Android Auto \*

Touch to enter the Android Auto interface.

- Video

Touch to enter the Video interface.

- Display Off

# Air Conditioning and Audio Systems

---

Touch  to turn off the display; touch again to wake up the display.

## **Power On/Off**

### *Power On*

If the vehicle power is turned off with the system currently in playback mode, the system will be automatically powered on when the vehicle power is turned on again.

If the vehicle power is turned off with the system in the Off state, short press the Power button on the system control panel to power-on the system after the vehicle power is turned on again.

With the system on, long press the HOME button on the system control panel to enter the Standby mode; keep pressing the button and the system will reboot automatically.

### *Power Off*

Pressing the START/STOP Switch to the Off position will automatically switch off the Infotainment system.

# Air Conditioning and Audio Systems

## Standby Mode

With the START/STOP Switch on, long press the HOME button to allow the Infotainment system to enter the Standby mode, the operation of the Infotainment system may be suspended.

In Standby mode, all sounds will be muted. To cancel the Standby mode, short press the HOME button.

The following operations can also cancel the Standby mode:

- The system automatically switches to the parking image during parking.
- Turn off the START/STOP Switch, the system shuts down directly.

## Control Buttons on Steering Wheel

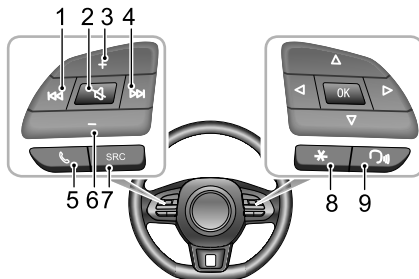

### I ◀◀ Button

When playing audio, short press to return to the beginning of the track (except the Bluetooth music mode), short press again to switch to previous track, and long press to rewind (except the Bluetooth music mode). When playing video, short press to switch to previous video, and long press to rewind. When playing radio, short press to automatically search for the previous station; long press to manually search for the previous station.

# Air Conditioning and Audio Systems

---

2  Button

Mute/Unmute.

3 Volume Up Button

4  Button

When playing an audio/video, short press to switch to next track/video (except the Bluetooth music mode), and long press to fast forward. When playing radio, short press to automatically search for the next station; long press to manually search for the next station.

5  Button

Short press to hang up if in calling/talking state; short press to answer and long press to reject if in incoming call state.

6 Volume Down Button

7 SRC Audio Source Switch Button

Switch to the next available media audio source.

8 “\*” Button on Steering Wheel

“\*” button on the steering wheel can be set as the shortcut key of SmartPhone / Home / Car.

9 Speech Recognition Function Button

Activate/Cancel speech recognition function. This button will only be used after Vehicle-Mobile Phone Interconnection \* is enabled.

## Volume Adjustment

The audio volume can be adjusted by the control panel and the buttons on the steering wheel. During the volume adjustment, the system automatically pops up a volume indication window which changes smoothly with the adjustment process.

**Note:** *The volume buttons on the steering wheel and control panel can only be used for the volume adjustment of audios of media and communication type.*

**Note:** *The playback volume of Bluetooth music can be adjusted by the device itself and the Infotainment player.*

## Connecting/Disconnecting a USB Storage Device

### *Inserting a USB Storage Device*

Connect a USB device to the USB port for connection.

### *Removing a USB Storage Device*

Check and confirm that there is no data being accessed, then pull out the USB storage device.

**Note:** *If data loss or damage to the storage device occurs for any reason, the data will generally never be recovered. For damages, costs or expenses due to data loss or damage, the manufacturer assumes no responsibility.*

**Note:** *Some USB storage devices may be unidentifiable.*

**Note:** *The Infotainment system may not achieve its optimum performance when using with some USB storage devices.*

**Note:** *Using USB hub or extension cable may not identify USB device.*

# Air Conditioning and Audio Systems

---

## Bluetooth Phone



### Instructions

- Connection to all mobile phones featuring Bluetooth wireless technology is not guaranteed.
- The mobile phone used must be compatible with the Infotainment system so that all functions of Bluetooth phone of the system can function correctly
- When using Bluetooth wireless technology, the Infotainment system may not operate all functions on the mobile phone.
- When transmitting voice and data via Bluetooth technology, the straight-line distance between the Infotainment system and the mobile phone should not exceed 10 metres. However, the actual transmission distance may be shorter than the estimated distance, depending on the usage environment.
- If Private mode is selected on the mobile phone, hands-free call function will be disabled.
- When the Infotainment system is turned off, the Bluetooth connection will be disconnected.
- Due to Bluetooth wireless connection, interruption or error occurring in the process of transmission in some

extreme cases, and the Infotainment system may be unable to be paired and connected with the mobile phone. At this time, it is recommended to clear the paired devices in the device list on the mobile phone and the Infotainment system, and conduct pairing again.







## Bluetooth Pairing and Connection

If Bluetooth is not enabled, no Bluetooth icon is displayed in the status bar; if Bluetooth is enabled but no device is connected,  is displayed in the status bar; if Bluetooth is enabled and any device is connected,  is displayed in the status bar.

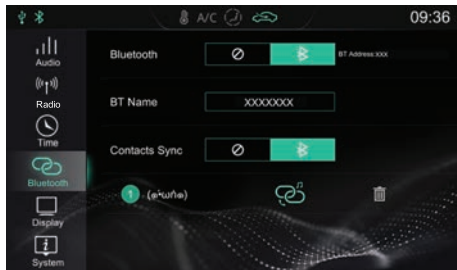
The steps of Bluetooth pairing and connection are as follows:

- Touch [Bluetooth] in the Settings interface to enter the Bluetooth connection settings interface, and touch  on the Bluetooth bar to enable the Bluetooth function.



- The system displays the Bluetooth address and the device name.
- Enable the Bluetooth on the mobile phone and search for the Infotainment system for pairing. The mobile phone will receive a Bluetooth Pairing request, after the pairing is completed, a prompt message of Connection Completed will appear. If the pairing fails, please repeat the above steps.
- Touch  to connect to the mobile phone Bluetooth, and touch  to disconnect the Bluetooth. Touch  to remove the mobile phone from the list of paired devices.



# Air Conditioning and Audio Systems

## Keypad

Touch [Keypad] in the Bluetooth Phone interface to enter the Dial Pad interface.



- 1 Paired Contacts
- 2 Input Box
- 3 Back/Delete Button
- 4 Make a Call

Touch  to make a call; when the Bluetooth phone is connected, touch  to end the call.

- 5 Input Keypad Area  
Input figures and symbols.

# Air Conditioning and Audio Systems

## Contacts

Touch [Contacts] in the Bluetooth Phone interface to enter the Contacts interface.

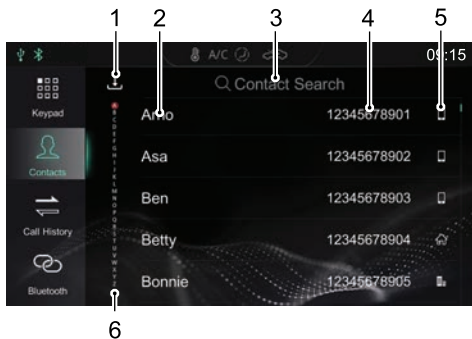

### 1 Download Contacts

When connected to a mobile phone via Bluetooth the entertainment system default setting will automatically download your contacts. The Auto Contacts Download function can be disabled or enabled in the Connections Setting Interface.

Click ↓ in the Contacts interface to download the Contacts manually.



### 2 Contact Name

### 3 Search for a Contact

Touch [Contact Search] in the interface, input the initial letter of the name to be searched, after the search is completed, touch the contact to make a call.

### 4 Phone Number

### 5 Phone Type

When a contact has multiple phone numbers, touch ,  or  to switch the phone number type and select the phone number to make a call.

### 6 Quick Contact Search

Touch the letter on the left of the interface or swipe the screen to quickly locate the contact with this letter as the initial letter.

**Note:** For some mobile phones, a dialog box asking whether to download Bluetooth phone contacts will pop up before downloading the Bluetooth phone contacts.

# Air Conditioning and Audio Systems

**Note:** Since the system temporarily does not support some commercially available mobile phones, the case of no synchronisation of Bluetooth phone book will occur on non supported phones.

## Call History

Touch [Call History] in the Bluetooth Phone interface to enter the Call History interface.

Touch the required call history record in the list to call the contact.

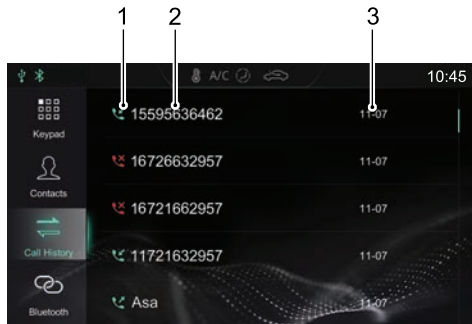

### I Call History Type

Dialed Calls: 

Received Calls: 

Missed Calls: 

- 2 Contact Name/Phone Number
- 3 Talk Time

Call History is arranged by time and date in reverse chronological order.

## Bluetooth Connection

Touch [Bluetooth] to enter the Bluetooth Connection interface. Refer to "Bluetooth Pairing and Connection" in this section for details.



## Making a Call

You may make a call using the following methods:

- Keypad Input: Refer to "Keypad" in this section for details.
- Call the number in Contacts: Refer to "Contacts" in this section for details.
- Call the number in Call History: Refer to "Call History" in this section for details.
- Make a call directly on the mobile phone.

## Ending a Call



You may end a call using the following methods:

- Touch  to hang up.
- Short press  on the steering wheel to hang up.
- Hang up on the mobile phone.



# Air Conditioning and Audio Systems

## Incoming Call

### Answer an Incoming Call

- Touch  to answer an incoming call.
- Short press  button on the steering wheel to answer an incoming call.
- Answer an incoming call on the mobile phone.

### Reject an Incoming Call

- Touch  to reject an incoming call.
- Long press  button on the steering wheel to reject an incoming call.
- Reject an incoming call on the mobile phone.

## Switch to Private Mode

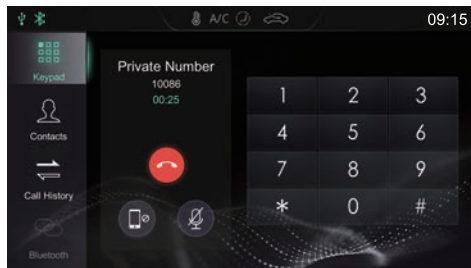

During a call, touch  to enter the Private Mode (Speaker Mode by default).

During a call, touch  to restore the Speaker Mode.

During a call, touch  to switch between Microphone Mute or Enabled function.

In Private Mode, you may continue with the call using the mobile phone; the speakers and microphone of the Infotainment system will be muted. But Bluetooth is still connected.

## Entertainment

### Precautions for Playing a Storage Medium

#### Mode

- The system supports USB drives and Bluetooth storage media.
- If the USB device media is not in use, DO NOT leave the device connected. This may result in connection deterioration.
- Do not remove USB device whilst media is playing. Failure to follow these instructions could result in corrupted data.
- Keep the USB port dry and free from debris. The port will become unusable if it is blocked.

#### Radio

Touch the Radio/Music area in the main interface, and touch [Radio] again to enter the Radio interface.



To listen to the broadcasting of different bands, touch [FM] or [AM] in the playback interface to switch between radio bands. Pressing the SRC button can also switch between the different radio bands.

#### FM/AM



- 1 Current Station Name or Frequency  
Touch [FM] or [AM] to switch the band.

- 2 Station Favorites State

 indicates that the station has been added to Favorites;  indicates that the station is not added to Favorites.

# Air Conditioning and Audio Systems

3 Display of Favorite Stations

4 Station List

5 List of Favorite Stations

6 Add a Station to/Remove a Station from Favorites

7 Station Preview

Automatically search and preview each station and play each for 10s. During the preview, click the button to terminate the preview function, and play the current previewing station.

8 Next Station

Short press to automatically search for the next station; long press to manually search for the next station.

9 Previous Station

Short press to automatically search for the previous station; long press to manually search for the previous station.

Touch [Audio] in this interface, and the system skips to the Audio Settings interface.

## USB Music

Insert a USB storage device into the USB port, and the system automatically loads the music from the storage device.

Touch the Radio/Music area in the main interface, and touch [USB Music] again to enter the USB Music Playback interface.

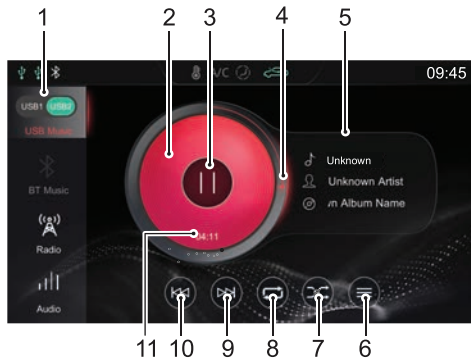



# Air Conditioning and Audio Systems

---

## 1 USB Drive

When there are two USB drives, you may choose to play music in USB1 or USB2.

## 2 Album Cover

## 3 Play/Pause

## 4 Track Playback Progress Bar

Track playback progress is displayed by the coil, drag the progress bar to skip to certain playing point.

## 5 Song/Artist/Album Name

## 6 USB Music List

Touch to enter the corresponding Folder List interface, then touch to select and play the track you prefer.

## 7 Random Playback Mode

You may switch between Random Playback and Folder Random Playback.

## 8 Loop Playback Mode

You may switch between Single Loop, Folder Loop and Loop All.

## 9 Next Track

Short press to switch to the next track; long press to fast forward.

## 10 Previous Track

Short press to switch to the previous track; short press during playing to return to the beginning of the track; long press to fast rewind.

## 11 Current Elapsed Time

Touch [Audio] in this interface, and the system skips to the Audio Settings interface.

# Air Conditioning and Audio Systems

## Bluetooth Music

Please connect a Bluetooth device first before playing Bluetooth music. Refer to "Bluetooth Pairing and Connection" in "Bluetooth Phone" section for details.

After the Bluetooth device is connected with the system, touch the Radio/Music area in the main interface, and then touch [BT Music] to enter the Bluetooth Music playback interface.

- 1 Play/Pause
- 2 Song/Artist/Album Name
- 3 Next Track
- 4 Previous Track

Touch [Audio] in this interface, and the system skips to the Audio Settings interface.

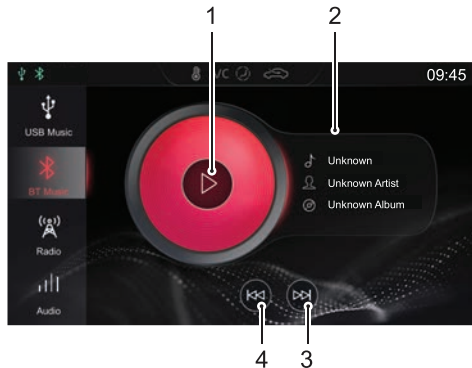

# Air Conditioning and Audio Systems

## USB Video

Insert a USB storage device into the USB port, and the system automatically loads the videos from the storage device.

**Note:** Due to differences in the compression ratio and bit rate of the multimedia formats downloaded from the Internet and other factors, the actual situation of the decoding result shall prevail.

**Note:** For your driving safety, when the vehicle speed reaches a certain value, the video safety mode will be activated automatically, the video cannot be played at that moment.

**Note:** The video cannot be played during a call.

Touch [Video] in the main interface to enter the Video Playback interface.

**Note:** When playing a video, click the screen to wake up the menu bar mode, and click it again to exit the menu bar mode.

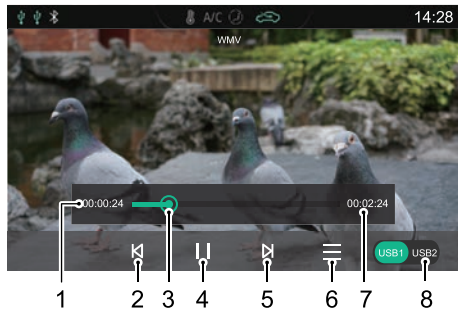

- 1 Current Elapsed Time
- 2 Previous Video  
Short press to switch to the previous video; long press to fast rewind.
- 3 Playback Progress Bar  
Drag the progress bar to skip to certain playing point.
- 4 Play/Pause
- 5 Next Video

2

# Air Conditioning and Audio Systems

---

Short press to switch to the next video; long press to fast forward.

## 6 Video List

You may view and play the corresponding video file.

## 7 Total Video Duration

## 8 USB Drive

When there are two USB drives, you may choose to play videos in USB1 or USB2.

## Pictures

Insert a USB storage device into the USB port, and the system automatically loads the pictures in the storage device.

Touch [Pictures] in the main interface to enter the picture Playback interface.

Touch a picture file to display it in full screen.

**Note: Whilst viewing a picture file, click the screen to wake up the menu bar mode, and click it again to exit the menu bar mode.**

# Air Conditioning and Audio Systems

## Picture Browsing Interface

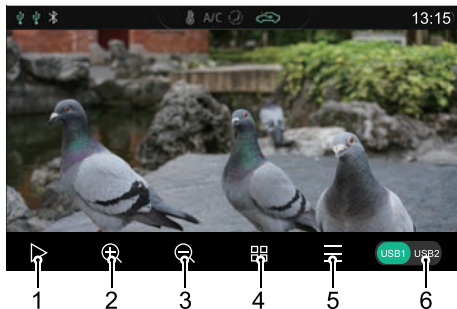

- 1 Slide Show
- 2 Zoom In
- 3 Zoom Out
- 4 Thumbnail
- 5 Pictures List
- 6 USB Drive

You may view and play the corresponding picture file.

When there are two USB drives, you may choose to view pictures in USB1 or USB2.

**Note:** The system supports the viewing of pictures stored on a USB device. Due to differences in picture resolution, format compression ratio and some other factors not all pictures may be decoded and displayed.

**Note:** Swipe to the left or right on the screen to switch to the next or previous picture.

# Air Conditioning and Audio Systems

---

## **Vehicle-Mobile Phone Interconnection \***

Only applicable to models that feature Vehicle-Mobile Phone Interconnection.

## **Apple CarPlay \***

Apple CarPlay enables information interaction between the mobile phone and the on-board Infotainment system, including map, music, telephone, short message, podcast, voice recognition .

### *Connection Method*

- 1 Confirm that your mobile phone has the Carplay function and that it is turned on.
- 2 Connect the mobile phone to the Infotainment system mainframe using the USB cable.
- 3 In the main interface, touch [Apple CarPlay] \* area to enter the Apple CarPlay interface.
- 4 After the vehicle and mobile phone are successfully connected, you can operate the iPhone using the Infotainment system screen.

- 5 Press the HOME button on the control panel to return to the main system interface.

## **Android Auto \***

Android Auto enables information interaction between the android mobile phone and the on-board Infotainment system, including map, music, telephone, messages, voice commands.

For the first time, download and install Android Auto in the application market.

When using , connect the mobile phone to the Infotainment system mainframe using the USB cable. In the main interface, touch [Android Auto] \* area to enter the Android Auto interface. Operate according to the interface prompt, then you can use the function once the connection is successful.

## **A/C**

Touch the A/C area in the main interface to enter the A/C System Settings interface. Refer to “Electronic Temperature Control” in this Manual for details.

## **Vehicle Settings**

Touch [Car] in the main interface to enter the Vehicle Settings interface.

### **Driving Assist \***

Touch [Driving Assist] in the Vehicle Settings interface to enter the Driving Assist Settings interface. You can set up the driving assistance system.

### **Comfort Convenience**

Touch [Comfort Convenience] in the Vehicle Settings interface to enter the Comfort Convenience Settings interface where the lights and other functions can be set.

### **Driving Maintenance**

Touch [Driving Maintenance] in the Vehicle Settings interface to enter the Driving Maintenance Settings interface. You can set up some driving control systems.

### **Factory Setting**

Touch [Factory Setting] in the Vehicle Settings interface to enter the Restore Factory Settings interface.

# Air Conditioning and Audio Systems

---

Touch [Reset] in the Factory Settings interface, and a Reset prompt appears. Please select as needed. Please use with caution.

## Settings

Touch [Setup] in the main interface to enter the Settings interface.

## Audio Settings

Touch [Audio] in the Settings interface to enter the Sound Settings interface. You can set the volume, EQ and sound stage.

## Radio Settings

Touch [Radio] in the Settings interface to enter the Radio Settings interface. You can set the radio area.

## Time & Date Settings

Touch [Time] in the Settings interface to enter the Time & Date Settings interface to set the date and time.

## Bluetooth Settings

Touch [Bluetooth] in the Settings interface to enter the Bluetooth Settings interface to set the Bluetooth connection function. Refer to “Bluetooth Pairing and Connection” in this section for details.



## Display Settings

Touch [Display] in the Settings interface to enter the Display Settings interface. You can set the brightness, backlight mode and so on.

## System Settings

Touch [System] in the Settings interface to enter the System Settings interface.

- You can view the help file, software version, hardware version and other information of the system.
- Touch [Start] to enter Restore Factory Settings interface, you can select to restore Audio, Radio lists, Other and all to default factory settings as required. After restoring factory settings, the mainframe is reset to its original settings and all data in the Infotainment system will be deleted. Please use with caution.



## **Seats & Restraints**

---

*106 Seats*

*111 Seat Belts*

*121 Airbag Supplementary Restraint  
System*

*129 Child Restraints*

---

# Seats & Restraints

---

## Seats

### Overview



**To avoid personal injuries due to the loss of control, DO NOT adjust the seats while the car is moving.**

The vehicle is equipped with 6-direction or 4-direction adjustable front seats and 60/40 split rear seats with foldable backrests.

An ideal position of the seat should make sure your driving position is comfortable, which allows you to hold the steering wheel with your arms and legs slightly bent and control all the equipment. Make sure your driving position is comfortable and enables you to maintain full control of the vehicle. Take care when adjusting the height of front seats - the feet of the rear passenger could become trapped when the seat is lowered.

Do not incline the front-seat backrest excessively. Optimum benefit is obtained from the seat belt with the backrest angle set to approximately 25° from the upright (vertical). The driver and front passenger seats should

be positioned as far rearward as practical. A properly adjusted seat helps reduce the risk of injury from sitting too close to an inflating airbag.

### Head Restraints



**Adjust the height of the head restraint so that the top of it is in line with the top of the occupant's head. This location may reduce the risk of head and neck injuries in the event of a collision. DO NOT adjust or remove the head restraints while the car is moving.**



**DO NOT hang anything on any head restraint or head restraint rod.**

The head restraint is designed to prevent rearward movement of the head in the event of a collision or emergency braking, thereby reducing the risk of head and neck injuries.

## Seats & Restraints

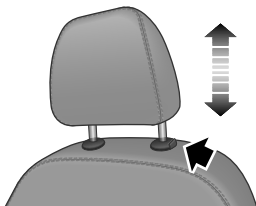

When adjusting a head restraint from low to high position, pull the head restraint directly upward, and gently press it downward after it reaches the desired position to make sure that it is locked in position. To remove the head restraint, press and hold the guide sleeve button (as indicated by the arrow) on the left of the head restraint, then pull the head restraint upward to remove it.

When adjusting a head restraint from high to low position, press the guide sleeve button (as indicated by the arrow) on the left of the head restraint, and press the head restraint downward; release the button after it reaches the desired position, and gently press the head restraint downward to make sure that it is locked in position.

### Front Seats

#### Manual Seat

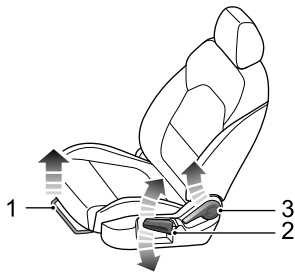

- Forward/Backward Adjustment

Lift the lever (1) under the seat cushion, slide the seat into an appropriate position and release the lever. Make sure that the seat is locked in place.

## Seats & Restraints

---

- Cushion Height Adjustment \*

Lift the lever (2) repeatedly to raise the seat cushion, and press the lever downward to lower the seat cushion.

- Backrest Adjustment

Lift the lever (3), adjust the backrest until it moves into a satisfiable position, and put down the lever.

### Power Seat \*

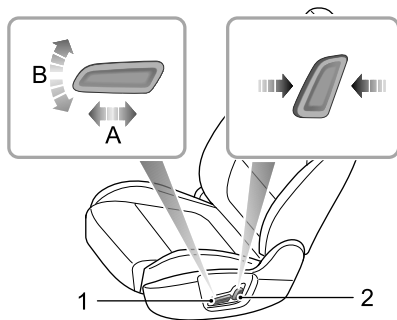

- Forward/Rearward Adjustment

Push the switch (1) forward or backward (A) to move the seat forward/backward.

- Cushion Height Adjustment

Pull the switch (1) upward or push downward (B) to raise or lower the seat cushion.

- Backrest Adjustment

Move the switch (2) forward/backward to adjust the backrest until it reaches the desired angle.

# Seats & Restraints

## Rear Seats



### Folding Rear Seats

To increase luggage space, first fully lower (or remove) all the rear seat head restraints, and then pull up the backrest unlock straps on both sides respectively and fold the seat backrests forward.

**Note:** When the head restraint of the rear seat is not fully lowered or the backrest of the front seat is

*inclined backward excessively, the folding of the rear seat is very likely to damage the back of the front seat, small storage compartment or head restraint of the rear seat.*

### Unfolding and Locking Rear Seat Backrests

When returning the rear seat backrest to the upright position, pull up the backrest unlock straps to release the locked state, push the backrest until it reaches an appropriate position, and the backrest is locked when you hear a click.



**Note:** When returning the rear seat backrest to the desired position, make sure that the rear seat belt is not trapped.

## Seats & Restraints

### Front Seat Heating \*



***If bare skin is in contact with the heated seats for excessive periods of time, it may cause burns.***

The seat cushion and backrest are provided with heating elements. After starting the engine, pressing  or  will activate the heaters.

When pressing a seat heater switch, the corresponding seat will become warm. Press the switch again to stop the heating function. When the seat heating function is activated, the operating indicator in the switch illuminates. When the cushion temperature reaches approximate 38°C or the backrest to approximate 40°C, the heating function will be deactivated automatically.

#### IMPORTANT

- Do Not cover the heated seats with blankets, cushions or other insulation type objects or materials.
- If the seat cushion is heated up to 38°C or the seat backrest is heated up to 40°C and continues getting hotter when using seat heating system, please turn off the seat heating and contact MG Authorised Repairer.
- Overuse of the driver's heated seat may cause drowsiness and could affect safety.



## Seats & Restraints

---

### Seat Belts



*It is important that all seat belts are worn correctly. Always check that all passengers are wearing seat belts. DO NOT carry passengers that are unable to wear correctly positioned seat belts. Wearing seat belts incorrectly may cause serious injury or even death in the event of a collision.*



*Airbags can not replace seat belts. Airbags can only provide extra support when triggered, and not all traffic accidents will trigger airbags. Whether airbags are triggered or not, seat belts can reduce the risks of serious injury or death in accidents. Therefore, seat belts must be worn properly.*



*NEVER unfasten a seat belt whilst driving, serious injury or death may occur in the case of an accident or emergency braking.*



*NEVER fasten the driver seat belt or use a buckle replacement when the driver seat is vacant or when exiting the vehicle. This could cause the engine to restart automatically.*



This vehicle is equipped with seat belt warning lamp to remind you to fasten your seat belt.

During driving, seat belts must be fastened, this is because:

- You can never predict if you will be involved in a collision accident and how serious it may be.
- In many cases of collision accidents, passengers with seat belts properly fastened are well-protected, while passengers with seat belts not fastened suffer from serious injury or even death.

Therefore, all passengers must wear seat belts correctly, even during short-distance journeys.

## Seats & Restraints

---

### Protection Provided by Seat Belts



*It is of equal importance for passengers in the rear seat to fasten their seat belts correctly. Otherwise, passengers with seat belts not correctly fastened will be thrown forward in accidents, and will endanger themselves as well as the driver and other passengers.*



When the vehicle is in motion, the travelling speed of the occupants is identical to that of the vehicle.

In the event of a 'head on collision' or emergency braking, the vehicle may stop, but the occupants will carry on travelling until they come into contact with a stationary object. This object may be the steering wheel, dashboard, windscreen or front seats.

A correctly fastened seat belt will eliminate this risk of injury. When the seat belt is worn correctly, it will lock automatically in collision accidents or emergency braking to reduce your speed together with the vehicle, so as to prevent the out-of-control movement which may cause serious injury to driver and passengers.

## Seats & Restraints

---

### Wearing Seat Belts



*Incorrectly worn seat belts could cause injury or death in the event of an accident.*



*Seat belts are designed for one person, DO NOT share seat belts.*



*DO NOT wrap a seat belt around when holding a baby or child in your arms.*



*Remove any heavy coats or clothing when wearing a seat belt, failure to do so can affect protection provided by the seat belt.*



*Seat belts should not be wrapped around hard or sharp objects such as pens, spectacles or keys.*



*Seat belts cannot function correctly when the seats are reclined excessively. DO NOT drive when the seats are excessively reclined.*

The seat belts fitted to your vehicle are designed for use by normal sized adults. This part of the literature refers to adult use.

All seat belts are 3 point lap-diagonal belts.

In order to maintain effective protection, the passengers must sit in the correct orientation, feet placed on the floor in front of them, with an upright body (no excessive recline) and the seat belt correctly fastened.

# Seats & Restraints

---

## Fastening Seat Belts

Please follow the instructions below to fasten the seat belts correctly.

- 1 Adjust the seat correctly.
- 2 Hold the metal tab, pull the seat belt out steadily over the shoulder and across your chest. Ensure there is no twist on the belt.

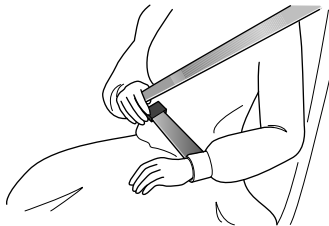

- 3 Insert the metal tab into the buckle until you hear a 'click', this indicates the seat belt is securely locked.

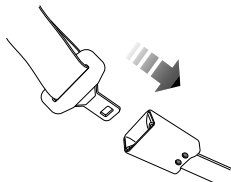

- 4 Remove any slackness in the belt by pulling up on the diagonal section of the belt.
- 5 To release the seat belt, press the red button on the buckle. The seat belt will retract automatically to its original place.

# Seats & Restraints

## IMPORTANT

- Always ensure the seat belt will not become trapped in the door aperture when closing the door, damage will occur.
- Pulling the seat belt out too quickly may cause it to lock. In this case, allow the seat belt to retract slightly and then pull it across your body slowly.
- If it is difficult to pull the seat belt out, it may be due to twisted webbing. If this is the case, fully extract the seat belt, remove the twist, allow the seat belt to retract slowly.
- When using the rear seat belts please ensure they are fully retracted into the correct position to avoid jamming in the rear seat catches. It is a legal requirement to wear seat belts. Even if the seat belt is twisted it must be worn. Where possible avoid the twisted section contacting the body and seek advice from an MG Authorised Repairer as soon as possible.

## Correct Routing of the Seat Belts



**Ensure the seat belt is correctly positioned on the body, never cross the neck or abdomen, never pass the seat belt behind the back or under the arms.**

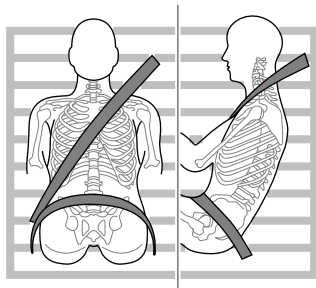

When wearing seat belts, the lap belt section should be positioned as low as possible across your hips, never across the abdomen. In the event of a collision, the lap belt can apply a force on the hips and reduce the possibility of you

## Seats & Restraints

---

slipping under the lap belt. If you slip under the lap belt, the belt will apply force on your abdomen, which may cause serious or fatal injuries. The diagonal section of the belt should cross the middle of the shoulder and the chest. In the event of emergency braking or collision, the diagonal section of the belt will be locked.

To ensure that the seat belts always provide maximum protection, ensure the belt is flat, not loose and contacts the body.

### Seat Belts Use during Pregnancy

Wearing correctly positioned seat belts will provide protection for both mother and unborn child in the event of a collision or emergency braking.



The diagonal section of the seat belt should pass across the chest as normal, the lap section of the belt should pass below the belly, low and snug on the hip bones. NEVER position the belt on or above the belly.

Please consult your physician for further details.

### Seat Belts and Disabilities

It is a legal requirement that all occupants wear seat belts, this include people with disabilities.

Depending upon the disability, consult your physician for further details.

# Seats & Restraints

## Children and Seat Belts



***Proper protection measures must be taken for children whilst travelling in the vehicle.***

For safety reasons, children must travel in suitable child restraint devices fixed to the rear seat.

## Infants



***Only recommended child restraints suitable for the age, height and weight of the child should be used.***



***NEVER carry a child or infant with your arms during driving. When collision accidents occur, the weight of a child will produce such a great force that you can not hold the child. The child will be thrown forward and suffer serious injury or even death.***

The seat belts fitted to your vehicle are designed for adults, they are not suitable for children. In the event of an accident or collision the children are not secure, it could cause death or serious injury.

Infants **MUST** use a suitable child restraint device. Please consult the child seat manufacturers guidelines when selecting the correct seat. Follow the manufacturers instructions on installation. Please refer to "Child Restraints" in this chapter for more details.

## Older Children



***NEVER share a seat belt amongst children. In the event of an accident or collision the children are not secure, it could cause death or serious injury.***

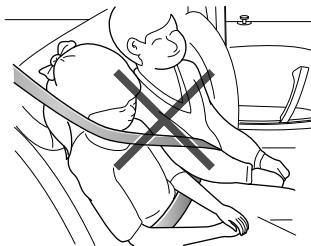

## Seats & Restraints

---

As children grow and become older/larger, it will get to the stage when they no longer require child seat restraints, at this point they will require use of the vehicle standard seat belt. Please ensure the seat belt is correctly positioned on the body of the child.

### Seat Belt Pre-tensioners



*The seat belt pre-tensioners will only be activated once and then **MUST BE REPLACED**. Failure to replace the pre-tensioners will reduce the efficiency of the vehicle's front restraint system.*



*If the pre-tensioners have been activated, the seat belts will still function as restraints, and must be worn in the event that the vehicle remains in a drivable condition. The seat belt pre tensioners should be replaced at the earliest opportunity by an MG Authorised Repairer.*

The vehicle is fitted with seat belt pre-tensioners, these are designed to retract the front seat belts and work

in conjunction with the airbags in the event of a severe collision. They are designed to retract the seat belt and 'secure' the occupant in the seat.

The airbag warning light on the instrument pack will alert the driver to any malfunction of the seat belt pretensioners.(see 'Warning Lamps and Indicators' in the 'Instruments and Controls' chapter).

The seat belt pre-tensioners can only be activated once, after activation they must be replaced. This may also involve replacement of other SRS components. Please refer to 'Replacing Airbag System Parts'.



# Seats & Restraints

## IMPORTANT

- Seat belt pre-tensioners will not be activated by minor impacts.
- The removal or replacement of a pre-tensioner must be carried out by the manufacturer trained, dealer technicians.
- 10 years from the initial date of registration (or installation date of a replacement seat belt pre-tensioner), some components will need to be replaced. The appropriate page of the Service Portfolio must be signed and stamped once the work has been completed.

## Seat Belt Checks, Maintenance and Replacement

### Seat Belt Checks



*Split, worn or frayed seat belts may not function correctly in the event of a collision, if there are any signs of damage, replace the belt immediately.*



*Always ensure the red release button on the seat belt buckle is pointing upwards to ensure easy release in the event of an emergency.*

Please follow the instructions below to regularly check whether the seat belt warning lamp, seat belt, metal tab, buckle, retractor and fixing device are working correctly:

- Insert the seat belt metal tab into the corresponding buckle and pull seat belt webbing close to the buckle quickly to check that the belt clasp locks.
- Hold the metal tab and pull the seat belt forward quickly to check that the seat belt reel locks automatically, preventing the webbing from extending.

## Seats & Restraints

---

- Fully extract the seat belt and visibly examine for twists, fraying, splits or worn areas.
- Fully extract the seat belt and allow to return slowly to ensure continual and complete smooth operation.
- Visibly examine the seat belt for missing or broken components.
- Ensure the seat belt warning system is fully functional.

If the seat belt fails any of the above tests or inspections contact an MG Authorised Repairer immediately for repairs.

### Seat Belts Maintenance



***Seat belt repairs should only be carried out by an MG Authorised Repairer.***



***Ensure no foreign or sharp objects become lodged in the seat belt mechanisms. DO NOT allow liquids to contaminate the seat belt buckle, this could affect the buckle engagement.***

Seat belts should only be cleaned with warm soapy water. Do not use any solvent to clean the seat belt. Do not attempt to bleach or dye the seat belt, it may weaken the seat belt. After cleaning, wipe with a cloth and allow to dry. Do not allow the seat belt to fully retract before it is completely dry. Keep seat belts clean and dry.

If there are contaminants accumulated in the retractor, the retraction of the seat belt will be slow. Please use a clean and dry cloth to remove any contaminants.

### Replacing Seat Belts



***Collision accidents may damage the seat belt system. The seat belt system may not be able to protect users after damage and may cause serious injury or even death when an accident occurs. After the accident, seat belts should be checked immediately and replaced as necessary.***

Seat belts should not require change after minor collisions, however, some other parts of the seat belt system may require attention. Please consult an MG Authorised Repairer for advice.

### Airbag Supplementary Restraint System

#### Overview



*The airbag SRS provides ADDITIONAL protection in a severe frontal impact only. It does not replace the need, or requirement to wear a seat belt.*



*The airbags together with the seat belts provide optimum protection for adults, but it is not the case for infants. The seat belt and airbag systems in the vehicle are not designed for protecting infants. The protection required by infants should be provided by child restraints.*

The Airbag Supplementary Restraint System generally consists of:

- Front Airbags (fitted to the centre of the steering wheel and dashboard above the glove compartment)
- Seat Side Airbags (fitted to the outer side of the seat squab)

- Side Head Impact Protection Airbags (fitted behind the headlining)

Please note that this is model and trim level dependant.

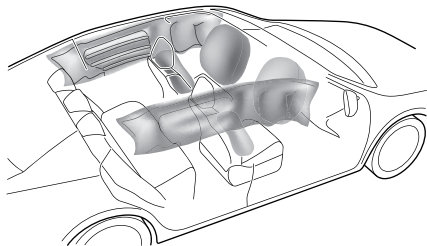

## Seats & Restraints

---

In the corresponding position where airbags are fitted, there is a warning sign stating 'AIRBAG'.

### Airbag Warning Light



The airbag warning light is located in the instrument pack. If this lamp does not extinguish or illuminates during driving, it indicates that there is a failure in the SRS or seat belt. Please seek an MG Authorised Repairer at the earliest opportunity. An SRS or seat belt fault may mean the components may not be deployed in the event of an accident.

### Airbag Deployment



*Front seat passengers should not place feet, knees or any other part of the body in contact with, or in close proximity to a front airbag.*



*To minimise the risk of accidental injury from inflating airbags, seat belts should be worn correctly at all times. In addition, both driver and front seat passenger should adjust their seat to provide sufficient distance from the front airbags. If side airbags/side head impact protection airbags are fitted, both driver and front seat passenger should be seated to maintain sufficient distance from the upper part of the body to the sides of the vehicle, this will ensure maximum protection when the side airbags/side head impact protection airbags are deployed.*

## Seats & Restraints

---



*When airbags are deployed, children without proper protection may suffer from serious injury or even death. DO NOT carry children in the arms or on the knees during traveling. Children should wear seat belts suitable to age. DO NOT lean out of windows.*



*An inflating airbag can cause facial abrasions and other injuries if the occupant is too close to the airbag at the time of its deployment.*



*DO NOT affix or place any objects on, or adjacent to the airbags. This may affect the airbag passage or create projectiles that may cause injury or serious harm in the event of airbag deployment.*



*After deployment the airbag components become very hot. DO NOT touch any airbag related components, it may cause burns or serious injury.*



*DO NOT knock or strike the position where airbags or related parts are located, so as to avoid accidental airbag deployment which may cause serious injury or even death.*

In the event of a collision, the airbag control unit monitors the rate of deceleration or acceleration induced by the collision, to determine whether the airbags should be deployed. Airbag deployment is virtually instantaneous and occurs with considerable force, accompanied by a loud noise.

Provided the front seat occupants are correctly seated and with seat belts properly worn, the airbags will provide additional protection to the chest and facial areas in the event of the car receiving a severe frontal impact.

Side airbags and side head impact protection airbags are designed to offer additional protection to the side of the body facing the impact, if a severe side collision occurs.

## Seats & Restraints

### IMPORTANT

- Airbags can not protect lower body parts of passengers.
- Airbags are not designed for rear collision, minor frontal or side impacts, or if the vehicle overturns; nor will it operate as a result of heavy braking.
- Deployment and retraction of the frontal and side airbags takes place very quickly and will not protect against the effects of secondary impacts that may occur.
- When an airbag inflates, a fine powder is released. This is not an indication of a malfunction, however, the powder may cause irritation to the skin and should be thoroughly flushed from the eyes and any cuts or abrasions of the skin.
- After inflation, front and side airbags deflate immediately. This provides a gradual cushioning effect for the occupant and also ensures that the driver's forward vision is not obscured.

### Front Airbags



***NEVER use a rearward facing child restraint on a seat protected by an ACTIVE AIRBAG in front of it, DEATH or SERIOUS INJURY to the CHILD can occur.***



***Front seat passengers should not place feet, knees or any other part of the body in contact with, or in close proximity to a front airbag.***



***In extreme cases driving on very uneven surfaces may cause airbag deployment. Please take extra care when driving on uneven roads.***

Airbags are designed to deploy during serious impacts, the following conditions may cause airbag deployment.

- A frontal collision with unmovable or non deformable solid objects at a high speed.
- Conditions that can cause serious chassis damage, such as a collision with kerbstones, road edges, deep ravines or holes.

## Seat Side Airbags \*



*The manufacture and material of the seat is critical to the correct operation of side airbags. Therefore, please DO NOT fit seat covers which may affect side airbag deployment.*

In the event of a serious side impact, the relevant side airbag will deploy (only the affected side).

- The airbag will be deployed in the event that the side of the vehicle is impacted with a solid object or another vehicle.

## Side Head Impact Protection Airbags \*

In the event of a serious side impact, the relevant side curtain airbag will deploy (only the affected side).

- The side curtain airbag will be deployed in the event that the side of the vehicle is impacted with a solid object or another vehicle.

## Conditions in Which Airbags Will Not Deploy

The deployment of airbags does not depend on the vehicle speed, but on the object that the vehicle hits, angle of impact and the rate at which the car changes speed as a result of a collision. When the impact force of collision is absorbed or dispersed to vehicle body, airbags may not deploy; however, airbags may sometimes deploy according to impact condition. Therefore, the deployment of airbags shall not be judged based on the severity of vehicle damage.

## Front Airbags

Under certain conditions the front airbags may not be deployed. Some examples are listed below:

- The impact point is not central to the front of the vehicle.
- The impact is not of sufficient force (the impact is with an object that is not solid, such as a lamp post or central barriers).
- The impact area is high (collision with the tailgate of a truck).
- Impacts to the rear or side of the vehicle.

# Seats & Restraints

---

- The vehicle rolling over.

## Seat Side Airbags and Side Head Impact

### Protection Airbags \*

Under certain conditions the seat side and side head airbags may not be deployed. Some examples are listed below:

- Side impacts at certain angles.
- Light side impacts such as a motorcycle.
- Impacts that are not central to the side of the vehicle, either too far toward the engine compartment or the loadspace.
- The vehicle rolling over.
- The angled impact is not of sufficient force (the impact is with an object that is not solid, such as a lamp post or central barriers).
- The impact is not of sufficient force (with another vehicle, stationary or moving).
- The impact is from the rear of the vehicle.

## Service and Replacement of Airbags

### Service Information



***DO NOT install or modify the airbag. Any changes to the vehicle structure or airbag system wiring harness are strictly prohibited.***



***Changes to vehicle structure is prohibited. This may affect the normal operation of the SRS.***



***DO NOT allow these areas to be flooded with liquid and DO NOT use petrol, detergent, furniture cream or polishes.***



***If water contaminates or enters the SRS it may cause damage and affect deployment. In this case contact an MG Authorised Repairer immediately.***

To prevent damage to the airbag SRS, the following areas should be cleaned sparingly with a damp cloth and upholstery cleaner ONLY:



# Seats & Restraints

- Steering wheel centre pad.
- Area of dashboard containing the passenger airbag.
- Area of roof lining and front pillar finishers which enclose the side head impact protection modules.

If the airbag warning lamp fails to illuminate, stays on, or if there is damage to the front or side of the vehicle, or the airbag covers show signs of damage, contact an MG Authorised Repairer immediately.

## IMPORTANT

- The removal or replacement of an airbag module should be carried out by an MG Authorised Repairer.
- After 10 years from the initial date of registration (or installation date of a replacement airbag), some components will need to be replaced by an MG Authorised Repairer. The appropriate page of the Service Portfolio must be signed and stamped once the work has been completed.

## Replacing Airbag System Parts



***Even if the airbag does not deploy, collisions may cause damage to SRS in the vehicle. Airbags may not function properly after damage, and can not protect you and other passengers when a second collision occurs, which may cause serious injury or even death. To ensure that SRS can function properly after collision, please go to an MG Authorised Repairer to check airbags and repair as necessary.***

Airbags are designed for using once only. Once the airbag is deployed, you must replace SRS parts.

Please go to an MG Authorised Repairer for replacement.

## Disposal of Airbags

When your vehicle is sold, ensure that the new owner knows the vehicle is equipped with airbags, and is aware of the replacement date of SRS.

If the vehicle is scrapped, the undeployed airbags may have potential risks, therefore, before the disposal, they must be

## Seats & Restraints

---

deployed safely in a certain environment by a professional from an MG Authorised Repairer.

# Seats & Restraints

---

## Child Restraints

### Important Safety Instructions about Using Child Restraints

It is recommended that children below the age of 12 years old should be seated on the rear seat of the vehicle, in a child restraint system appropriate to the children's weight and size. Infants less than 2 years old should be restrained in an infant child restraint system.

It is recommended that a child restraint system that complies with UN ECE-R44 or ECE-R129 standard are fitted in this vehicle. Check markings on the child restraint system.

There are a number of child restraint systems available of different type and specification. For optimum protection, it is recommended that you choose restraint systems appropriate to the child's age and weight.

It is important to comply with installation instructions supplied by the child restraint manufacturer and that child restraint system is properly secured to the vehicle. Failure to follow these instructions may cause death or serious injury to the child in an event of a sudden stop or accident.

- All occupants, including children must wear seat belts or use an appropriate child restraint.
- It is recommended that children under 12 years of age or less than 1.5 metres tall should use the appropriate child restraint fitted to the rear seat.
- Only one child can be carried in any one restraint.
- Do not put the child on the lap or in arms when sitting in any seat.
- If installing a rear facing child restraint to the rear seat, the corresponding front seat should be adjusted forward; if installing a forward facing child restraint to the rear seat, you may need to adjust the height of the headrest to the lowest; if installing a forward facing child restraint to the front seat, you may need to remove its headrest.
- Never let your child stand or kneel on the seat during driving.
- Always ensure the child is seated correctly in the child restraint.
- The ways of using seat belts have a great influence on the maximum protection offered by the seat belt, you must comply with the child restraint manufacturer's instructions on proper use of seat belts. If seat belts

## Seats & Restraints

are not properly fastened, a minor traffic accident may also lead to injury.

- Child restraints that are not fitted correctly may move and injure other occupants in the event of an accident or emergency braking. Therefore, even if there is no infant or child in the child restraint, it also should be fitted properly and securely in the vehicle.

### Warnings and Instructions on Use of Child Restraint on Front Passenger Seat



*When the front passenger airbag is active, never install a rear facing child restraint on the front passenger seat, severe injury or even death can occur.*



*When installing a child restraint on the front passenger seat, move the front passenger seat as far rearward as possible.*



*Use one child restraint per child.*

Please study the safety warning label on the sun visor. Where possible always install child restraints on the rear seat. If it is necessary to install a child restraint on the front seat please observe the warnings above.

### Children's Safety and Side Airbags\*



*Children should not be allowed in areas where airbags may be deployed, there is a risk of serious injury.*



*Only recommended child restraints suitable for the age, height and weight of the child should be used.*

## Seats & Restraints



**DO NOT place any items in areas where airbags may be deployed, there is a risk of serious injury.**

In the event of a side collision, the side airbags can provide better protection for the passenger. However, when the airbag is triggered a very strong expansion force is generated, if the passenger's seating position is not correct, the airbags or items in the side airbag deployment area may cause injury.

When the correct child restraint is used to secure the child properly in the rear seat and the child's seating position is correct, there is enough space between the child and the side airbag deployment region for the airbag to deploy without any hindrance, and thus provide the best protection.

### Child Restraints Groups

#### Secured Using 3 Point lap Diagonal Belts



**Please DO NOT put the rear facing child restraint in the front passenger seat, this may cause serious injury or even death.**

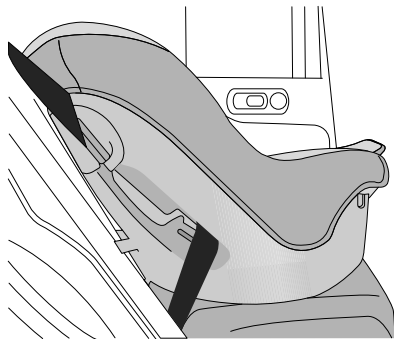

## Seats & Restraints

It is recommended that children should always be seated in the rear of the vehicle in a child restraint or restraint system, and fixed with 3 point, lap diagonal seat belts.

### ISOFIX Child Restraint Systems



*The ISOFIX anchorages in the rear seat are designed for use with ISOFIX systems only.*



*Child restraint anchorages are designed to withstand only those loads imposed by correctly fitted child restraints. Under no circumstances are they to be used for adult seat belts, harnesses, or for attaching other items or equipment to the vehicle.*

**Note:** When installing and using any child restraint system, always follow the manufacturer's instructions.

**Note:** The rear seats fitted to this vehicle are provided with the ISOFIX interface (as indicated by the arrow in the following image), these are designed to connect to an ISOFIX child seat.

- 1 Fasten vehicle-approved ISOFIX child restraint systems to the mounting brackets.

- 2 When using ISOFIX mounting brackets for seat mounting, universally approved child restraint systems for ISOFIX may be used.

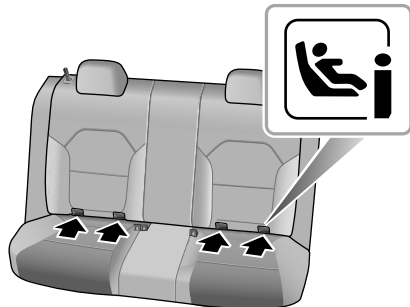

## Seats & Restraints

---

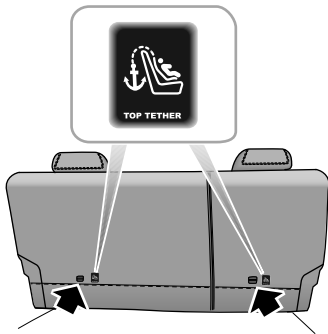

**Note:** When using seat mounting, universally approved child restraint systems, Top-tether must be used.

- 4 After installation apply suitable force to ensure the restraint is securely fastened.

- 3 To fasten the Top tether strap of the child restraint system, route the tether strap under the head restraint and attach to the anchorage hook being careful not to twist the strap. If not using ISOFIX lower anchorages, using the seatbelt, complete the installation in line with the child restraint manufactures instructions.

## Seats & Restraints

### Approved Child Restraint Positions

It is recommended that a child restraint system that complies with UN ECE-R44 or ECE-R129 standard are fitted in this vehicle. Check markings on the child restraint system.

### Approved Child Restraint Positions (for non ISOFIX Child Restraints)

Mass Group	Seating Positions		
	Front Passenger	Rear Outboard	Rear Middle
0 group (less than 10 kg)	X	U	X
0+ group (less than 13 kg)	X	U	X
I group (9 ~ 18 kg)	X	U	X
II group (15 ~ 25 kg)	U	U	X
III group (22 ~ 36 kg)	U	U	X

Note: Description of letters in the table:  
U = Suitable for universal child restraint systems approved for this mass group;  
X = Seat position not suitable for child restraint systems in this mass group.



## Seats & Restraints

### Approved Child Restraint Positions (for ISOFIX Child Restraints)

Seating Position		Mass group categories			
		0 group	0+ group	I group	
		Rear facing		Forward facing	Rear facing
		Up to 29 lbs(13 kg)		20–40 lbs(9 ~ 18 kg)	
Front Passenger Seat	Size Class	Not ISOFIX equipped			
	Seat Type				
Rear Outboard Seat ISOFIX	Size Class	C,D,E <sup>1</sup>	A,B, BI <sup>1</sup>	C,D <sup>1</sup>	
	Seat Type	IL <sup>2</sup>	IL <sup>2</sup> ,IUF <sup>3</sup>	IL <sup>2</sup>	
Rear Centre Seat	Size Class	Not ISOFIX equipped			
	Seat Type				

Note: IL Suitable for particular ISOFIX child restraints systems of the semi-universal category. Please consult child restraints systems suppliers' vehicle recommendation lists;

IUF Suitable for ISOFIX forward facing child restraints systems of universal category approved for use in this mass group and ISOFIX size class;

<sup>1</sup>. The ISOFIX size class for both universal and semi-universal child seat systems is defined by the capital letters grade A ~ G. These identification letters are displayed on the ISOFIX child seat;

## Seats & Restraints

---

- <sup>2</sup>. At time of publishing the recommended Group 0+ ISOFIX baby safety seat is the Britax Romer Baby Safe. Consult an MG Authorised Repairer for the latest details relating to our recommended child seats;
- <sup>3</sup>. At time of publishing the recommended Group I ISOFIX child seat is the Britax Romer Duo. Consult an MG Authorised Repairer for the latest details relating to our recommended child seats.

**Note: At time of publishing the recommended Group II-III ISOFIX child seat is the KidFix XP. Consult an MG Authorised Repairer for the latest details relating to our recommended child seats.**

### Table of I- Size child seats

The table gives a recommendation for which I- Size child seats suit which locations, and for what size of child.

The child seat must be approved in accordance with UN Reg R129.

Type of child seat	Front passenger seat	Rear outboard seats	Rear centre seat
I- Size child restraint systems	X	I-U	X

Note: I-U Suitable for use with forward and rear facing I- Size child restraint systems.

X Not suitable for use with I- Size restraint systems.

## Seats & Restraints

### Group 0/0+ Child Restraint



*When the front passenger airbag is active, never place a rear facing child restraint on the front passenger seat, severe injury or even death can occur.*

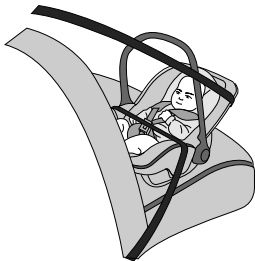

Child restraints that can be adjusted to lying position are most suitable for infants who are lighter than 10 kg (normally for those younger than 9 months) or those who are lighter than 13 kg (normally for those younger than 24 months).

### Group I Child Restraint



*When the front passenger airbag is active, never place a rear facing child restraint on the front passenger seat, severe injury or even death can occur.*



Backward/forward child restraints are most suitable for infants whose weight is 9 ~ 18 kg (normally for those older than 9 months and younger than 4 years old).

## Seats & Restraints

---

### Group II Child Restraint



*The diagonal section of the seat belt should pass across the shoulder and upper body, away from the neck. The lap section of the belt should pass across the hips,, away from the abdomen.*



The combination of child restraint and 3 point lap diagonal seat belt is most suitable for children whose weight is 15 ~ 25 kg (normally for those older than 3 years old and younger than 7 years old).

### Group III Child Restraint



*The diagonal section of the seat belt should pass across the shoulder and upper body, away from the neck. The lap section of the belt should pass across the hips, away from the abdomen.*



The combination of child booster seat and vehicle 3 point lap diagonal seat belt is most suitable for children whose weight is 22 ~ 36 kg and whose height is below 1.5 m (normally for those about 7 years old or those older than 7 years old).

## Starting & Driving

---

- 140 Keys
  - 143 Child Proof Locks
  - 144 Alarm System
  - 150 Starting and Stopping Engine
  - 156 Economical and Environmental Driving
  - 160 Catalytic Converter
  - 162 Fuel System
  - 164 6-Speed Automatic Transmission \*
  - 171 Continuously Variable Automatic Transmission \*
  - 177 Manual Transmission \*
  - 179 Brake System
  - 191 Stability Control System (SCS) and Traction Control System (TCS)
  - 193 Cruise Control System \*
  - 196 Active Speed Limit (ASL) System \*
  - 198 Parking Aid System
  - 202 Rear Driver Assistance System \*
  - 208 Tyre Pressure Monitoring System (TPMS)
  - 210 Loading
-

# Starting & Driving

## Keys

### Overview



**Keep the spare key in a safe place - not in the vehicle!**



**It is recommended that spare keys are not kept on the same key ring, since this may cause interference and prevent correct key recognition and therefore prevent the engine from starting.**



**The smart key contains delicate electronic components and must be protected from impact and water damage, high temperature and humidity, direct sunlight and the effects of solvents, waxes and abrasive cleaners.**

Your vehicle is supplied with two smart keys, each one contains a back up mechanical key blade, this will operate the driver door mechanical lock. The smart keys supplied are programmed to the security system on the car, any key

that is not programmed to the car will not operate the keyless entry function or the vehicle immobiliser.

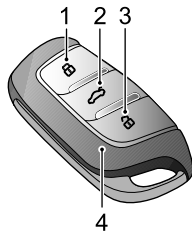

- 1 Lock Button
- 2 Tailgate Button
- 3 Unlock Button
- 4 Smart Key

The smart key only works within a certain range. Its working range is sometimes influenced by the key battery condition, physical and geographical factors. For safety consideration, after you lock your vehicle by the smart key, please recheck if the vehicle is locked.

## Starting & Driving

If your key is lost/stolen or broken, a replacement can be obtained from an MG Authorised Repairer. The lost/stolen key can be deactivated. If the lost key is found, an MG Authorised Repairer can reactivate it.

**Note:** Any key made independently outside of MG Authorised Repairer Network may not start the engine, and may affect the safety of your car. To obtain a suitable key replacement, it is recommended that you can consult MG Authorised Repairer.

**Note:** The new key cannot be offered to you immediately because it requires programming to the vehicle by the MG Authorised Repairer.

**Note:** When operating your vehicle with the smart key, avoid placing it near the devices with strong radio interference (such as notebook computers and other electronic products), the normal function of the key may be affected.

### Replacing the Battery

Please use the picture guide to replace the smart key battery if any of the following conditions occur:

- The smart key locking/unlocking function range is reduced;
- The engine immobilisation warning lamp on the instrument pack flashes (Refer to "Warning Lamps and Indicators" in "Instruments and Controls" section).

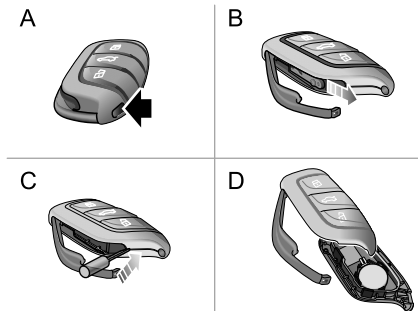

- 1 Press the button (A) on the smart key to eject the decorative trim.
- 2 Remove the backup mechanical key (B) in the arrowed direction.

## Starting & Driving

- Using a suitable flat bladed tool, insert the tool into the side of the key (C), carefully prise off the battery cover and separate the upper and lower casings (D).
- Remove the battery from the slot.
- Put the new battery in the slot, and make sure it is in full contact with the slot.

**Note:** *Make sure that the polarity of battery is correct ('+' side facing down).*

**Note:** *It is recommended to use a CR2032 battery.*

- Refit the cover and press tightly, ensuring the gap around the cover is even.
- Refit the mechanical key, and close the decorative trim.
- Start the engine to resynchronise the key with the vehicle.

### IMPORTANT

- Use of an incorrect or inappropriate battery may damage the smart key. The new replacement's rated voltage, sizes and specifications must be the same as the old one.
- Incorrect fitting of the battery may damage the key.
- Disposal of the used battery must be strictly in accordance with relevant environmental protection acts.



### Child Proof Locks



**NEVER** leave children unsupervised in the vehicle.

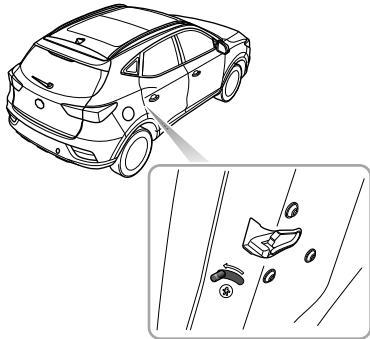

- Move the lever to the unlock position in the reverse direction of the arrow to disable the child proof lock. With the child proof lock locked, the rear door at the corresponding side cannot be opened from inside the car, but can be opened from outside the car.

Steps for enabling or disabling the child proof locks are as follows:

- Open the rear door at corresponding side, move the child proof lock lever to the lock position in the direction of the arrow to engage the child proof lock;

## Alarm System

Your car is fitted with an anti-theft alarm and power immobilisation system. To ensure maximum safety and operation convenience, we strongly recommend you to carefully read this chapter to fully understand the activation and deactivation of anti-theft systems.

## Engine Immobilisation

Engine Immobilisation is designed to safeguard the vehicle from theft. Engine Immobilisation can only be deactivated to start the engine by using the matched key.

## Engine Immobilisation

Press the START/STOP Switch on the instrument panel, once a valid key is detected in the vehicle, immobilisation system will be deactivated automatically.

If the message centre displays "Smart Key Not Detected" or "Put Key Into Back-up Position" or the power immobiliser system warning lamp illuminates, please put the smart key at the bottom of the centre console cup holder or storage compartment (refer to "Alternative Starting Procedure" in "Starting and Stopping Engine" section), or try to use the

spare key. If the car can still not be started, please contact MG Authorised Repairer.

## Anti-theft System

### Locking and Unlocking

When the vehicle is locked, the indicator lamps flash three times and the anti-theft system turns on; when it is unlocked, the indicator lamps flash once and the anti-theft system turns off.

#### *Operation of Door Lock System (Key)*

##### **Key Locking**

- Using the remote key to lock: press the lock button on the key to lock the car after closing the doors, bonnet and tailgate.
- Using the mechanical key to lock: partially operate the door release handle, using a suitable flat blade tool, insert the tool into the underside of the trim and carefully remove the door lock trim cover, insert the key into the driver door lock and turn clockwise to lock the car.

##### **Key Unlocking**

- Using the remote key to unlock: press the unlock button on the key to unlock the car.

- Using the mechanical key to unlock: partially operate the door release handle, using a suitable flat blade tool, insert the tool into the underside of the trim and carefully remove the driver door lock trim cover, insert the key into the driver door lock and turn counterclockwise to unlock the car.

**Note:** *If the START/STOP Switch is not placed in ACC or ON/RUNNING position within 15 seconds after the vehicle is unlocked with the mechanical key, the engine immobilisation alarm will be triggered.*

**Note:** *If no panels are opened within 30 seconds after the vehicle is unlocked by using the remote key, all doors will automatically re-lock.*

#### *Operation of Door Lock System (Keyless)*

The keyless entry system can lock and unlock the doors and tailgate as long as you carry the smart key and approach to the car.

#### IMPORTANT

The smart key must be within 1.5 metres of the vehicle for the keyless system to operate correctly.

## Starting & Driving

### Keyless Locking

After switching the vehicle power system to OFF using the START/STOP Switch and exiting the car, press the door handle button once before moving away from the car to lock all doors, charge point door and tailgate (no need to press the lock button on the key). Note, this will also arm the alarm and immobilise the vehicle.

### Keyless Unlocking

Press the button on the front door handle once to unlock the car, then pull the door handle to open the door.

**Note:** *When the vehicle is locked, if you are within the smart key range and operate the door handle button, but carry out no further action, after 30 seconds the vehicle will automatically re-lock itself to remain secure.*

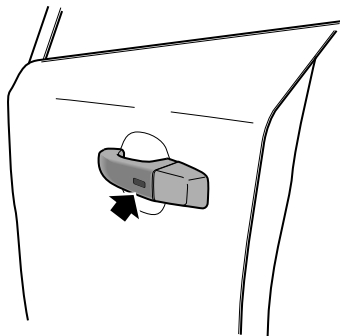

#### IMPORTANT

After the door is locked by using the key, press the button on the door handle to unlock the car. If the car cannot be unlocked or locked normally, seek an MG Authorised Repairer.

### Mislock

If the driver's door is not fully closed when the smart key lock button is pressed, or the START/STOP Switch has not been switched OFF, the vehicle horn will sound once, indicating a mislock. In this case, none of the doors will lock, the alarm system will not be armed.

If the driver's door is closed, the passenger door, bonnet and tailgate are not fully closed, the horn sounds once to indicate mislock when the car undergoes locking operation. However, the 'partial arming' attributes of the security system will enable as much of the system to be armed as possible (all fully closed doors, bonnet or tailgate apertures will be protected, but an open door will not!). The alarm indicator will flash. As soon as the open aperture is closed, the system will automatically revert to an armed state

### Anti-theft Alarm Sounder

If the anti-theft alarm has been triggered, the car horn will sound continuously. Press the UNLOCK button on the key, the anti-theft alarm will be deactivated.

### Interior Lock and Unlock Switch

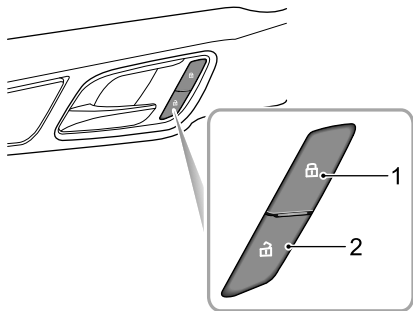

- 1 Lock Switch
- 2 Unlock Switch

When the anti-theft alarm system is not in operation, press the lock switch (1) to lock all doors; press the unlock switch (2) to unlock all doors.

# Starting & Driving

---

**Note:** *If the anti-theft alarm system is switched on, pressing the lock/unlock button will not lock/unlock the doors but will trigger the alarm system.*

If the doors, bonnet and tailgate are closed, press the interior lock switch. The yellow indicator on the interior lock switch illuminates.

If a mislock is caused by non-driver door, tailgate or bonnet, press the interior lock switch. The yellow indicator on the interior lock switch illuminates.

## Interior Door Handles

Use the interior door handle to open the door:

- 1 Pull the interior door handle once to unlock the door.
- 2 Pull the interior door handle again to open the door.

## Speed Lock

All the doors will be locked automatically when the road speed exceeds 10 mph (15 km/h).

## Automatic Unlock

When the vehicle power system is switched to the OFF position, all the doors will be unlocked automatically.

## Tailgate



*If the tailgate can not be closed due to the type of cargo loaded, be sure to close all windows during driving, select the face distribution mode of the air condition, and set the blower to maximum speed, so as to decrease exhaust fumes entering the vehicle.*

## Tailgate Open Mode

The tailgate can be opened by using the following 2 methods:

- When the vehicle is unlocked or the matched key appears within 1m range around the tailgate, directly open the tailgate by turning over the emblem on the tailgate (Figure A).
- When START STOP switch in the OFF position, press the release button on the remote key (Figure B) for more than 2 seconds to open the tailgate.

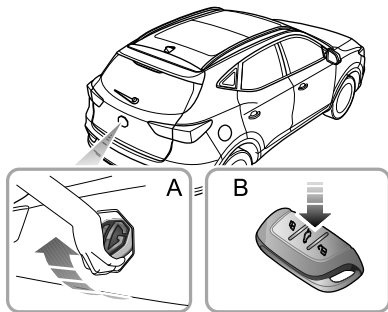

## Emergency Tailgate Opening

The emergency tailgate release access is located in the centre of the tailgate trim.

Fold down the rear seat to gain access, remove the blanking plug, and rotate the emergency open knob counterclockwise to open the tailgate from inside.

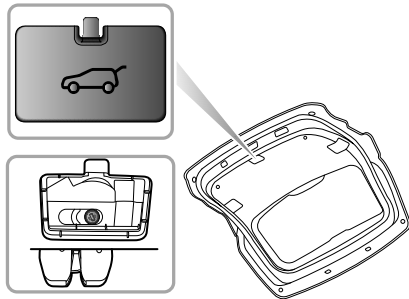

### Starting and Stopping Engine

#### START/STOP Switch



The keyless START/STOP Switch is located in the fascia to the right of the steering column, it is a push button style switch.

**Note:** To operate the system, the remote key must be in the car. To leave the parking gear, the START/STOP Switch must be in ONIRUNNING position, and the brake pedal must be depressed.

The operational status displays are as follows:

#### **Indicator Off (OFF)**

- The engine is shut off in this position.

#### **Yellow Light (ACC)**

- Some electrical equipment can be operated, such as power windows.
- When the engine is shut off, press the START/STOP Switch button once and do not depress the brake pedal to turn the START/STOP Switch to ACC position.

#### **Green Light (ON/RUNNING)**

- All electrical equipment are operational.
- Drive and start the vehicle.
- When the START/STOP Switch illuminates yellow, if the brake pedal is not depressed, press the START/STOP Switch again, the engine will not start, but the vehicle enters green light state.

**Note:** After turning the START/STOP Switch to Position OFF and opening the door, if the key is still left in the vehicle, the audible warning will sound when closing the door, to remind you that the key is still in the vehicle.



If your car is subject to strong radio signals the keyless entry and start systems may suffer from interference and not function correctly. Please see the "Alternative Starting Procedure".

### Starting the Engine

#### Starting the Engine:

- 1 Switch off all unnecessary electrical equipment (including the air conditioning);
- 2 Apply the parking brake (refer to "Brake System" of this section);
- 3 For auto transmission vehicles, Ensure P or N is selected and press the brake pedal .
- 4 For manual transmission vehicles, ensure neutral is selected and the clutch pedal is fully pressed.
- 5 Press the START/STOP Switch (do not hold the button in, release immediately).

## Starting & Driving

---

### Alternative Starting Procedure ( Auto Transmission )

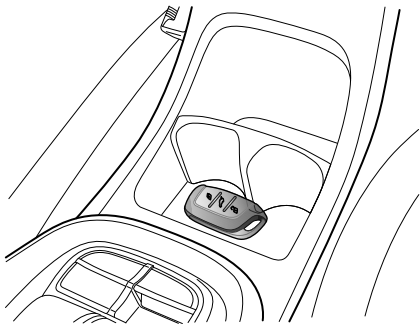

- 2 Place the smart key centrally in the centre console cup holder cubby box with the buttons facing upward - as shown in the illustration.
- 3 Ensure P or N is selected, press the brake pedal and then press START/STOP Switch to start the vehicle.

If the immobiliser cannot be released after the car has left the area of strong radio interference or had the smart key battery replaced please consult an MG Authorised Repairer.

If the car is located in an area where there are strong radio signals causing interference or the smart key battery condition is low, please use the following steps to attempt to start the car:

- 1 For vehicles with cup holder, remove the cup holder .

# Starting & Driving

## Alternative Starting Procedure ( Manual Transmission )

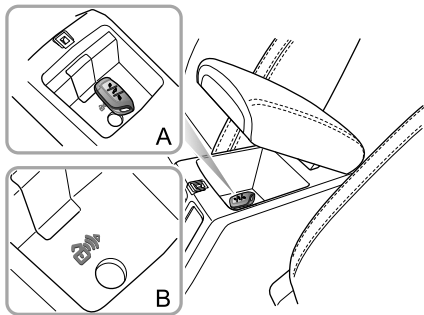

If the car is located in an area where there are strong radio signals causing interference or the smart key battery condition is low, please use the following steps to attempt to start the car:

- 1 Place the smart key centrally in the centre console cup holder cubby box with the buttons facing upward - as shown in the illustration.
- 2 Press the clutch pedal and press START/STOP Switch to start the vehicle.

If the immobiliser cannot be released after the car has left the area of strong radio interference or had the smart key battery replaced please consult an MG Authorised Repairer.

### Precautions for Starting the Engine

Idle speed will decrease after engine warm-up. Do not increase engine speed immediately after engine starts. Progressively operate the engine and transmission so that oil can preheat and lubricate all operating components.

DO NOT press the accelerator pedal while starting and DO NOT operate the starter for more than 15 seconds at a time.

In temperatures of  $-10^{\circ}\text{C}$  and below, engine cranking times will increase. It is essential that all unnecessary electrical equipment is switched off while cranking.

# Starting & Driving

## IMPORTANT

- If the vehicle will not enter a ON/RUNNING state, please check for any warning indicators or messages displayed in the instrument pack message centre. In extremely low temperatures please allow 5 minutes between starting attempts, if after 3 attempts the vehicle will not start please consult an MG Authorised Repairer or breakdown service.
- DO NOT leave the ignition switch in the ACC, ON/RUNNING or START positions for any length of time when the engine is not running, otherwise it may lead to battery discharge due to the use of electrical equipments.
- The vehicle is fitted with engine immobilisation system. Any independently made key cannot start the engine.
- Your car is controlled by electronic control systems. When starting the engine, please make sure there are no electronic devices that can create electromagnetic interference near the vehicle. This may cause issues with the electronic control systems on the vehicle.

## Stopping the Engine

Stop the engine as follows:

- 1 After bringing the car to a stop, continue to apply the footbrake until the parking brake is applied;
- 2 Apply parking brake;
- 3 For vehicles with automatic transmission, ensure that the shift lever is in P position.
- 4 For vehicles with manual transmission, ensure that the shift lever is in neutral position.
- 5 For vehicles with key start , turn the key from ON/RUNNING position to LOCK/OFF position, the engine will be shut down and the key can be removed.
- 6 For vehicles with keyless start , press START/STOP Switch to shut down the engine.

**Note:** *For vehicles with keyless start , when the engine needs to be stopped in emergency, please press START/STOP Switch and hold for more than 4 seconds to stop the engine.*

**Note:** *After strenuous towing or driving at high speed (particularly in hot weather), it is suggested*

## Starting & Driving

---

*to allow the engine to idle for a few minutes before switching off, which enables the cooling system to work continuously to lower the engine temperature.*

# Starting & Driving

---

## Economical and Environmental Driving

### Running-in

The engine, transmission, brakes and tyres need time to 'bed-in' and adjust to the demands of everyday motoring. During the first 1,500 km, it is essential that you drive with consideration for the running-in process and heed the following advice:

- Do not allow the engine to exceed 3000 rpm in any gear or the vehicle speed to exceed 120 km/h.
- Do not operate at full throttle or allow the engine to labour in any gear.
- Do not drive at a constant speed (either high speed or low speed).
- Avoid heavy braking where possible.

After 1,500 km, engine speeds can be gradually increased.

### Environment Protection

Your vehicle has been designed with the latest technology in order to minimize the environmental impact of exhaust emissions.

## Driving Style

The way in which you drive your car has a significant bearing on environmental pollution, as well as affecting the amount of fuel you use.

### Avoid full throttle acceleration

Steady, rather than rapid, acceleration uses considerably less fuel, reduces exhaust pollutants and also minimizes the wear to mechanical components.

### Avoid driving at maximum speed

Fuel consumption, exhaust emissions and noise levels all increase significantly at high speeds.

### Do not drive in a low gear for longer than necessary

Driving in lower gears uses more fuel and creates more noise. Change up to a higher gear as soon as possible, provided it does NOT cause the engine to labour.

## Drive smoothly

Anticipating obstructions and slowing down well in advance, avoids the need for unnecessary acceleration and harsh braking. A smooth driving style not only reduces fuel consumption, but can reduce the emission of noxious gases.

## Driving in rain



***Emergency braking, accelerating and steering on slippery roads will reduce the vehicle's handling performance and grip.***

When raining the windows may fog, reducing visibility (Use the Air-conditioning demist function).

Grip will be reduced, so please drive carefully.

Reduce speed when it rains.

Avoid aquaplaning (the effect of a film of water between the tyres and the road) affecting steering and braking performance.

Your MG is equipped with Brake Disc Wiping, activated by the wipers or rain sensor (where fitted). This will help

to keep the brake pads and discs clear of water and help restore brake performance.

Avoid driving through floods after heavy rain, which may lead to serious damage to the vehicle.

## Fuel Saving and Extending Vehicle Life

The following are some suggestions on saving fuel and extending the life of the vehicles.

- Maintain the correct tyre pressure; insufficient air pressure will accelerate tyre wear and waste fuel.
- Do not carry unnecessary weight. Heavy loads will increase the engine load resulting in higher fuel consumption.
- Avoid engine idling for extended periods.
- Maintain slow and smooth acceleration and avoid harsh acceleration; change to a higher gear as soon as possible.
- Avoid labouring the engine or over running. Choose appropriate gears according to the road conditions.
- Avoid continuous acceleration or deceleration. A stop-go driving style will consume more fuel.
- Avoid unnecessary stopping and braking, maintain steady speed and attempt to anticipate traffic lights.

## Starting & Driving

---

- Keep an appropriate distance from other vehicles to avoid emergency braking and reduce brake pad wear.
- Avoid traffic congestion and jam areas as much as possible.
- Do not ride the brake pedal, this can cause premature wear, overheating and increased fuel consumption.
- Maintain an appropriate speed on the highway. Higher speeds use more fuel. Appropriate speed can save fuel.
- Maintain the correct wheel alignment. Avoid collision with the kerb and reduce speed on uneven road surfaces. Out of specification wheel alignment will not only lead to excessive tyre wear, but also increases the engine load and fuel consumption.
- Avoid driving on mud or beaches. This will prevent corrosion of the vehicle underside.
- Maintain the vehicle in accordance with MG recommendations. Dirty air filters, oil etc., will reduce the engine's performance and raise fuel consumption. To extend the life of all components and reduce operating costs, regular MG Approved maintenance is needed.
- Do not stop the engine straight after high speed or long ascents or towing a trailer. Allow the engine to idle for

20 to 100 seconds depending upon driving loads and conditions. Avoid hard acceleration on a cold engine.



## **Maintenance**

### **Have the vehicle regularly serviced**

Regular servicing will ensure optimum fuel consumption and minimize exhaust pollutants, as well as effectively extending the service life of the car.

### **Check tyre pressures regularly**

Under-inflated tyres increase the rolling resistance of the car which, in turn, increases fuel consumption. Over or under-inflated tyres wear out more rapidly and also have a detrimental effect on the car's handling characteristics.

### **Do not carry unnecessary loads**

The additional weight of unnecessary loads wastes fuel, especially in stop/start conditions where the car is frequently required to set off from stationary.

### Catalytic Converter



**DO NOT** let the vehicle pass through or park on the road or ground with combustible materials such as hays or leaves etc which can come into contact with the exhaust system to avoid fires.

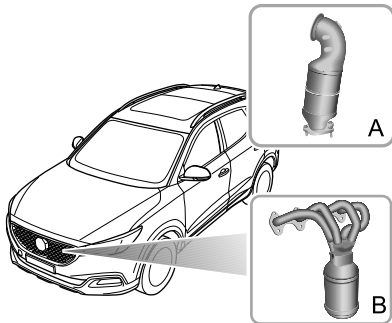

The exhaust system incorporates a catalytic converter, which converts poisonous exhaust emissions from the engine into environmentally less harmful gases. Depending on different models, the vehicles are equipped with different three-way catalytic converters: three-way catalytic converter for 1.3T models (A) and three-way catalytic converter for 1.5L models (B).

Improper use may lead to damage to the catalytic converter, so please pay special attention to the following requirements to minimize the possibility of damage.

#### **Fuel**

- Only use the recommended fuel.
- Never allow the vehicle to run out of fuel - this could cause a misfire which could damage the catalyst.

#### **Starting**

Pay attention to the followings when starting the engine:

- Do not continue to operate the starter after a few failed attempts; seek an MG Authorised Repairer.
- Do not start the engine by depressing the accelerator pedal repeatedly after the failed attempt.

## Starting & Driving

---

- Do not attempt to start the vehicle by pushing or towing.

### **Driving**

Pay attention to the followings when driving the vehicle:

- Do not overload or excessively revolve the engine.
- Do not allow the flameout when the vehicle is driving with a gear engaged. If the vehicle equipped with a manual transmission needs to slow down while traveling in high gear, downshift immediately to avoid insufficient driving force.
- If the vehicle consumes too much oil, please have the vehicle serviced immediately, as it will reduce the engine performance.
- If a misfire is suspected, or the vehicle lacks power while driving, please have it serviced at an MG Authorised Repairer.
- Do not drive on terrain likely to subject the underside of the vehicle to heavy impacts.

**Note: Unauthorised engine modification is prohibited. Because engine modification may result in engine misfire, loss of engine power or engine shaking, etc. which could seriously damage the catalytic**

**converter. Regular maintenance must be carried out in accordance with the schedule specified in the 'Service Portfolio'.**

## Fuel System

### Fuel Requirements



***Use only the recommended fuel which meets national standard! Serious damage to the catalytic converter, a reduction in engine power/torque and increase in fuel consumption will occur if the wrong fuel is used.***

Please use the fuel which is recommended and certified by the manufacturer. See 'Major Parameters of Engine' in 'Technical Data'.

If a lower grade of fuel is used, an engine knocking noise may occur, please use the recommended or above grade fuel as soon as possible. If the engine knocking noise is still noticeable after using the recommended or above grade fuel, please contact MG Authorised Repairer immediately.

### Safety Precautions in a Fuel Filling Station



***Vehicle fuel gases are highly flammable and, in confined spaces, are also extremely explosive.***

Always take care when refueling:

- Switch off the engine.
- Do not smoke or use a naked flame.
- Do not use a mobile phone.
- Avoid spilling fuel.
- Do not overfill the tank.

## Fuel Filler

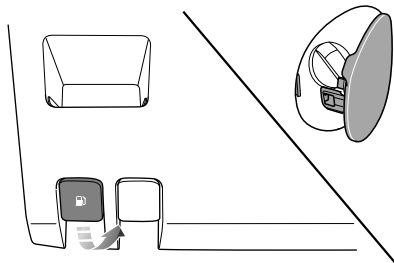

## Fuel Filler Flap

The fuel filler flap is located on the rear right-hand wing. Pull the fuel filler flap release handle under the driver side instrument pack to open the flap.

## Fuel Filler Cap

Unscrew the filler cap anti-clockwise and allow any pressure inside the tank to escape, before removing the cap.

After refueling, tighten the filler cap clockwise until you hear one "click" sound.

## Refueling

Do not fully fill the tank if the vehicle is to be parked in direct sunlight, or high ambient temperature - expansion of the fuel could cause spillage. The fuel filler tube is designed to accept a narrow, long filler nozzle. There is a cover at the filler neck, by inserting the filler nozzle thoroughly before fuel filling, the cover can be fully opened.

Start the engine after fuel filling. After refueling, if the engine runs unevenly, switch off and seek an MG Authorised Repairer before attempting to restart the engine.

# Starting & Driving

## 6-Speed Automatic Transmission \*

### Instructions

The following information is very important, please read carefully before use.

- Before starting the engine, place the gear lever in P or N position, ensure the foot brake is pressed and the parking brake is applied.
- After the engine has started, ensure the foot brake and parking brake are applied, shift the lever to the required gear.
- Release the parking brake and hold the foot brake until you are ready to manoeuvre the vehicle. Once the foot brake is released, on flat road, the vehicle will automatically start off at a slow speed without application of the accelerator.
- Do not move the gear shift lever into P or R from D whilst driving, this will cause severe transmission damage or cause an accident.

### Gear Shift

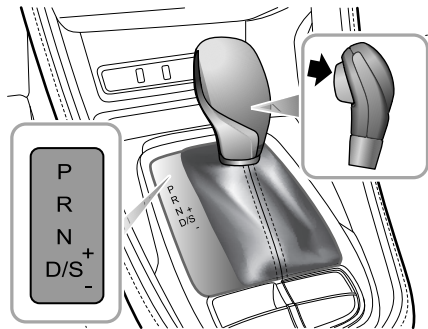

The automatic transmission is a 6 speed transmission.

**Note:** *The highlighted letters or numbers in the information centre indicate the selected gear or mode.*

A sprung loaded lock button, located in the gear lever, is used to prevent mistakingly selecting P (Park) or R (Reverse) whilst the gear selector is in other positions.

# Starting & Driving

## Shift Lever Operation



**Unless necessary, it is not recommended to press lock button during gear shifting.**

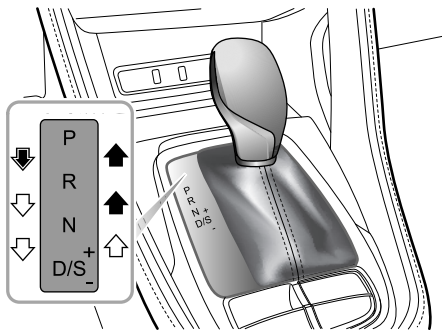

During the gear shift, operate the shift lever according to the instructions indicated by the following arrows:



Free gear shift.



Press and hold the lock button to shift the gear.



Press and hold the lock button and apply the brake pedal to shift gear.

## Shift Lever Position



**The shift lever must be placed in P position when parked.**



**DO NOT move the gear shift lever into P or R from D whilst driving, this will cause severe transmission damage or cause an accident.**

- P Park

When the shift lever is in this position, the transmission will be mechanically locked. Use this gear only when the vehicle is stationary and the parking brake is applied.

# Starting & Driving

---

**Note:** *When the vehicle is parking on a hill, press the brake pedal and apply the parking brake first and then select P gear.*

- R Reverse

Select this gear only when the vehicle is stationary and the engine is running at idle speed.

- N Neutral

Select this gear when the vehicle is stationary and the engine is running at idle speed for a short time (for example, waiting for traffic lights).

- D Drive

This is used for normal driving and will allow automatic selection of 6 gears depending on vehicle speed and accelerator position.

- S Sport Mode

Select this mode when a more sporty acceleration performance is required.

- + Upshift

Whilst in Tiptronic mode, upshift the transmission to the next available high gear.

- - Downshift

Whilst in Tiptronic mode, downshift the transmission to the next available low gear.

## Gearshift Speed

Selecting D will allow the transmission controller to carry out gearshifts taking in consideration of a number of factors including engine speed, vehicle speed and accelerator position. Light accelerator pedal application will result in a gear-change at low speeds, larger pedal applications will result in gear-changes at higher speeds.

## Kick-down



***The drive wheels may skid when kick-down is activated on road surfaces with low adhesion, this may lead to the vehicle sliding out of control.***

With D gear selected, pressing the accelerator pedal all the way down in one motion (also known as Kick-down) will provide better acceleration performance during overtaking. Under certain conditions, it will allow the transmission to shift to a lower gear immediately, and provide fast acceleration. Once the accelerator pedal is



released, it will resume to a suitable normal high gear (based on the vehicle speed and the position of the accelerator pedal).

### Driving on the Hill



*In cases where a short stop on a hill is required, such as a traffic jam, DO NOT momentarily apply the accelerator to prevent “roll back”. This could cause the transmission to overheat and result in damage.*

### Hill Start

In cases of a hill start, where the vehicle has been stationary for some time, the foot brake has been released and the electronic parking brake applied, the starting assist function of the electronic parking brake (EPB) can be used to prevent the vehicle from rolling backwards. With the seat belt safely fastened, press the foot brake, apply the electronic parking brake system, and select the desired gear (D/R/S), then release the foot brake; press the accelerator pedal to engage vehicle drive, the electronic parking brake system will automatically be deactivated.

Models fitted with Hill Hold Control can use this function to assist hill starts. For details on hill hold control system, please refer to "Foot Brake" of "Brake System" section.

# Starting & Driving

---

**Note:** *The assistance of these functions cannot defy the laws of physics. DO NOT drive the vehicle beyond its physical limitations, loss of control will still occur.*

## Downhill Driving



**Repeated application of the footbrake may result in the brakes becoming overheated. This will cause a reduction in braking performance and may even result in brake failure.**

If driving down a hill for long distances, it is advised to move the gear shift lever to the right and select the Tiptronic mode. This allows manual gear selection. Use a lower gear selection to aid the slowing of the vehicle and thus avoiding over-use of the brakes. If a threshold is reached, the vehicle will automatically shift up, in these cases use of the brakes to slow the vehicle is necessary, at the same time re-select the lower gear.

## Control Mode

### Economy Mode

Selecting D automatically places the vehicle in the Economy Mode. The information centre display will show "D". Economy Mode provides optimum fuel consumption and emissions.

### Sport Mode

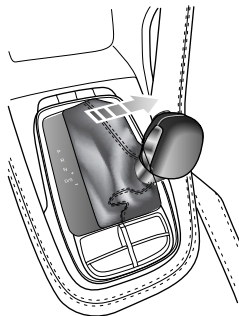

Once D is selected, move the shift lever to the right to select S and enable the Sport Mode (the gear displayed in information centre changes to "S"). Under Sport Mode, the transmission upshifts later, so as to make full use of the power reserves of the engine .

When better acceleration is required, please select the Sport Mode, but please note that the fuel consumption will be increased when driving in Sport Mode.

To exit Sport Mode, move the shift lever to the left back into D position.

### Cruise Control Mode \*

With the cruise control function enabled, the transmission will switch to the relevant gear for the vehicle speed automatically, thereby avoiding frequent gear shifts when the system needs to maintain a constant speed.

### Tiptronic Mode

With Sport Mode selected, move the shift lever toward "+" or "-", this will enable Tiptronic Mode. The gear displayed in the information centre will indicate current gear with a single number (1 ~ 6).

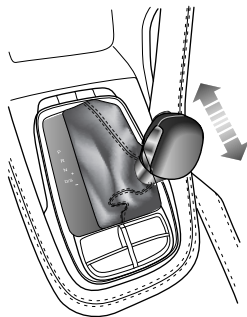

Move the shift lever toward "+" direction to upshift to next available high gear, move toward "-" direction to downshift to next available low gear.

With Tiptronic Mode selected, if the driver makes an unreasonable gear selection, requests an upshift during low engine speeds, or requests a downshift during high engine speeds, the transmission will not respond and will remain in the current gear. If the vehicle is driven and the engine speed falls below a preset threshold in certain

gears, the transmission will automatically shift down to the next gear to avoid engine stalling; when the vehicle accelerates, if the engine speed exceeds a preset limit, the transmission will automatically shift up to the next gear to protect the engine.

To return to Sport Mode or any other modes, shift the lever across to the left and select D.

### **Automatic Transmission Failure**

If the automatic transmission develops a problem, the engine emission malfunction indicator lamp in the instrument pack will illuminate or the message centre will display “EP”.

Some “failure modes” will cause the transmission to enter “Limp Mode”, during this time only certain gear positions can be selected and/or work, for example, R gear may not be selectable. If a serious functional failure occurs the vehicle cannot be driven, please consult an MG Authorised Repairer immediately.

**Note:** *Under limp mode, Tiptronic functions are disabled.*

## Continuously Variable Automatic Transmission \*

### Instructions

The following information is very important, please read carefully before use:

- Before starting the engine, place the shift lever in P or N position, ensure the foot brake is pressed and EPB is applied.
- After the engine has started, ensure the foot brake and EPB are applied, shift the lever to the required gear.
- Turn off the EPB system and hold the foot brake until you are ready to manoeuvre the vehicle. Once the foot brake is released on flat road, the vehicle will automatically start off at a slow speed without application of the accelerator.
- During driving, DO NOT coast in neutral, or it could damage the transmission or cause an accident.
- DO NOT tow with front wheels on the ground, or it could damage the transmission.

### Gear Shift

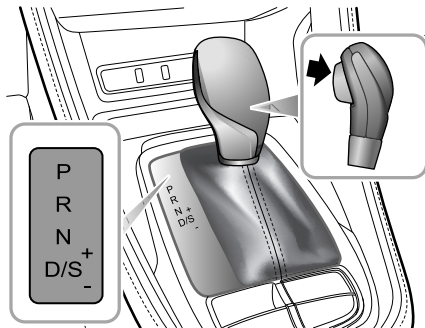

The automatic transmission is a continuously variable transmission .

**Note:** *The figure or letter in the message centre shows the selected gear.*

A lock button with spring located in the gear lever, is used to prevent mistakenly selecting P (Park) or R (Reverse) whilst the gear lever is in other positions.

# Starting & Driving

## Shift Lever Operation



**Unless necessary, it is not recommended to press lock button during gear shift.**

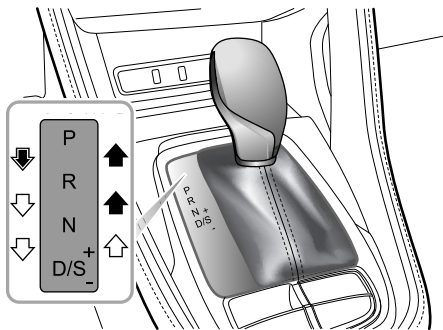

During the gear shift, operate the shift lever according to the instructions indicated by the following arrows:



Free gear shift.



Press and hold the lock button to shift gear.



Press and hold the lock button and step on the brake pedal to shift gear.

## Shift Lever Position



**The shift lever must be placed in P position when parking.**



**During driving, do not switch the shift lever between D and R or switch to P position, otherwise the severe damage to automatic transmission or dangerous accident may occur.**

- P Park

When the shift lever is in this gear, the transmission will be locked. Use this gear only when the vehicle is stationary and the EPB is applied.

**Note: When the vehicle is parking on a hill, press the brake pedal and apply the EPB first and then select P.**

# Starting & Driving

---

- R Reverse

Select this gear only when the vehicle is stationary.

- N Neutral

Select this gear when the vehicle is stationary and the engine is running at idle speed for a short time (for example, waiting for traffic lights).

- D Drive

This is used for normal driving and will allow automatic selection of Drive gear depending on vehicle speed and accelerator pedal position.

- S Sport

Select this mode when better acceleration performance is required.

- + Upshift

Under Tiptronic mode, upshift the transmission to the next available high gear.

- - Downshift

Under Tiptronic mode, downshift the transmission to the next available low gear.

## Gearshift Speed

With D or S gear selected, the speed at one gear varies depending on the accelerator pedal position: a smaller throttle opening will result in the gear shift at a lower speed, and a larger throttle opening will render the transmission to delay the gear shift action, until the gear shift is completed when the vehicle reaches a higher speed.

## Kick-down



***The drive wheels may skid when kick-down is activated on road surfaces with low adhesion, this may lead to the vehicle sliding out of control.***

With D or S gear selected, pressing the accelerator pedal all the way down in one motion (also known as kick-down) will provide better acceleration performance during overtaking. Under certain conditions, it will allow the transmission to shift to a lower gear immediately, and provide fast acceleration. Once the accelerator pedal is released, it will resume a suitable higher gear (based on the vehicle speed and the position of the accelerator pedal).

## Driving on Hills



*In cases where a short stop on a hill is required, such as a traffic jam, DO NOT momentarily apply the accelerator to prevent “roll back”. This could cause the automatic transmission to overheat and result in damage.*

## Hill Start

In case of hill start, the starting aid function of electronic parking brake (EPB) can be used to prevent from slipping. With the seat belt safely fastened, depress the foot brake, apply the electronic parking brake system, and engage into the desired gear (D/R/S), then release the foot brake; depress the accelerator pedal for start-off, the electronic parking brake system will automatically deactivated for starting aid.

You can also use the hill hold control function to hill start. For details on hill hold control system, please refer to "Foot Brake" in "Brake System" chapter.

*Note: The aid of these functions cannot defy the laws of physics. DO NOT drive the vehicle beyond its physical limitations, loss of control will still occur.*

## Downhill Driving



*Repeatedly pressing the brake pedal may result in brake overheat, thereby causing the degradation of brake performance or even brake failure.*

If driving down a hill for long distances, slow down first, and then push the shift lever from D gear to the right and enter into Tiptronic mode, then manually engage in low gear. Use a lower gear selection to aid the slowing of the vehicle and thus avoiding over-use of the brakes. For example, when driving down the hill with continuous curves, engage into 2 gear; when driving down the straight hill, engage into 3 gear. If the brake force of engine is insufficient, the speed is increased, the automatic transmission will shift to high gear automatically to avoid the overrunning of the engine, at this time, you need to press the brake pedal immediately and shift to appropriate low gear through Tiptronic mode.



## Control Modes

### Standard Mode

With the shift lever in D position, the automatic transmission enters into standard mode by default automatically, and the message centre will display "D" gear. The standard mode is used for daily driving.

### Sport Mode

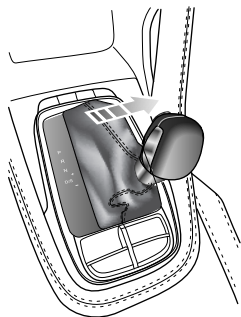

With the D position selected, move the shift lever rightwards to S gear to enable the sport mode ("S" is presented on the message centre). In sport mode, the transmission upshifts some time later, so as to make full use of the power reservation of the engine.

When better acceleration is required, select sport mode, but please note that the fuel consumption will be increased when driving in sport mode.

To cancel sport mode, move the shift lever leftwards to D gear.

### Tiptronic Mode

With sport mode selected, move the shift lever toward "+" or "-", this will enable the Tiptronic mode. The gear displayed in the message centre will indicate the current gear with a single number (1 ~ 8).

**Note:** In Tiptronic mode, the transmission has 8 simulated gears.

## Starting & Driving

---

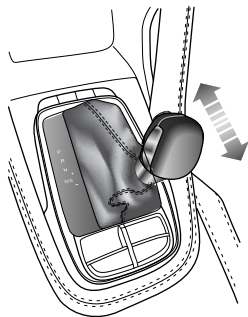

Toggle the shift lever towards "+" direction to upshift to next available high gear; or toggle the shift lever towards "-" to downshift to next available low gear.

In Tiptronic mode, if the driver makes an unreasonable gear selection, such as requests an upshift during low engine speeds, or requests a downshift during high engine speeds, the transmission will not respond and will remain in the current gear. If the vehicle is driven and the engine speed falls below a preset threshold in certain gears, the

transmission will automatically shift down to the next gear to avoid engine stalling; when the vehicle accelerates, if the engine speed increases continuously and exceeds the allowable maximum speed but no upshift request received, the transmission will automatically shift up to the next gear to protect the engine.

To return to other gear modes, move the shift lever leftwards and select D.

### Transmission Failure

When the transmission has some faults, the engine emission malfunction indicator lamp in the instrument pack illuminates. When some faults occur, the transmission will enter Limp Mode and the vehicle will only function in some gears; while in individual cases it may fail to reverse. If some severe functional malfunctions occur, the vehicle will be inoperative.

**Note: If this happens, seek an MG Authorised Repairer immediately.**

**Note: In Limp Mode, the Tiptronic mode function is disabled.**

## Manual Transmission \*

### 5-speed Manual Transmission

#### Shift lever

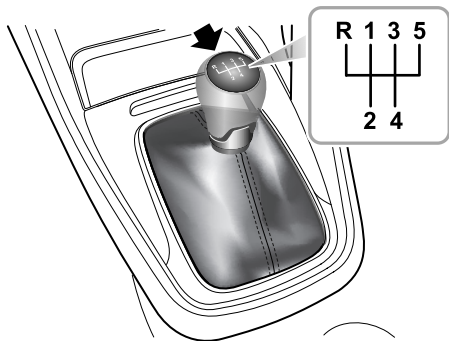

The manual transmission is a 5-speed transmission with 6 gears, which are: 1st, 2nd, 3rd, 4th, 5th, R (Reverse) respectively.

#### Precautions while driving:

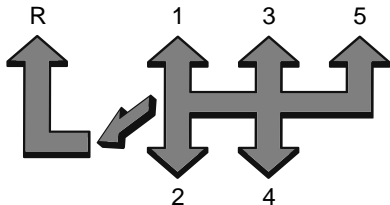

- 1 When selecting Reverse gear, you must ensure that the vehicle is completely in stationery, wait for a moment and then fully press the clutch pedal, from the N position, press the lever down and push it leftward, then push it forward into the R position, slowly release the clutch pedal to complete the gear shift.
- 2 Do not rest your hand on the shift lever while driving - pressure from your hand may cause premature wear to the gear shift mechanism.
- 3 Do not rest your foot on the clutch pedal when driving - excessive wear to the clutch may occur.

## Starting & Driving

---

- 4 Do not park the vehicle on a slope by engaging in a gear. This will result in excessive wear to the clutch.

### Gearshift Suggestions

Gear	Recommended shift range (km/h)	Engine Speed (RPM)
1st-2nd Gear	16 ~ 20	2200 ~ 2800
2nd-3rd Gear	28 ~ 35	2200 ~ 2800
3rd-4th Gear	45 ~ 50	2200 ~ 2500
4th-5th Gear	60 ~ 70	2200 ~ 2500

**Note:** *In order to guarantee the smooth driving and good fuel economy of the vehicle, please shift at an appropriate time, and never allow the tachometer pointer to remain in the red sector for prolonged periods, otherwise the engine may be damaged.*

## Brake System

### Foot Brake

For added safety, the hydraulic braking system operates through dual circuits. If one circuit should fail, the other will continue to function, but greater pedal pressure will be needed, and increased brake pedal travel, and longer stopping distances will be experienced. In the event of a brake failure where only one circuit is operational, the car should be brought to a halt as soon as traffic conditions safely allow. DO NOT continue driving - seek an MG Authorised Repairer.

### Servo Assistance

The braking system is servo assisted, always be aware of the followings during the operation:

- The servo assistance functions with the engine running only. Never allow the car to coast with the engine turned off.
- Always take particular care when being towed with four wheels on the ground and the engine turned off. If the engine should stop for any reason while driving, bring the car to a halt as quickly as traffic conditions safely

allow, and do not pump the brake pedal as the braking system will lose any remaining servo assistance.

- Once the engine has stopped it will lose any remaining servo assistance, use suitable force to apply the brake pedal to stop the car safely in the current traffic conditions. Contact an MG Authorised Repairer.
- Efficiency of the brake servo booster can be affected by numerous conditions, such as engine speed loss. These conditions could result in extra force required to operate the brake pedal to stop the car.

### Electronic Brake Force Distribution (EBD)

Your car is equipped with Electronic Brake Force Distribution, which, in order to maintain braking efficiency, distributes braking forces between front and rear wheels, under all load conditions.

EBD integrates a monitoring system. The monitoring system is linked to the brake system malfunction indicator lamp on the instrument pack. Refer to "Warning Lights and Indicators" in "Instruments and Controls" section.

If the indicator lamp illuminates while driving, or remains illuminated after the START/STOP Switch is switched

ON/RUNNING, it indicates there is a failure with the braking system, and EBD may be inoperative. In such a case, stop the car as soon as safety permits and seek an MG Authorised Repairer immediately. DO NOT drive the car with the braking system malfunction indicator lamp illuminated.

### Electronic Brake Assistance (EBA)

Your car is equipped with Electronic Brake Assist, which reacts to the speed at which the brake pedal is applied. If, in an emergency situation the brakes are applied faster than the limits set within the system, then full ABS application is applied to bring the car to a stop in the shortest possible distance.

### Hill Hold Control (HHC)



***HHC has limitations when subject to adverse conditions such as wet or icy surfaces and steep slopes.***



***HHC is not a substitute for parking brake application when carrying out a hill start. DO NOT exit the vehicle with only HHC applied, it may lead to a serious accident when HHC releases.***



***The car may roll if 'pull-away' is not achieved immediately after releasing the brake pedal.***



***Always ensure the brake pedal is pressed or electronic parking brake applied until drive is taken up.***



***Firm application of the brake pedal when stopping is required by HHC to generate sufficient brake pressure to maintain hold.***

HHC assists the driver by 'holding' the vehicle during hill starts.

The following conditions must be fulfilled to activate HHC:

- The driver's door is closed and the driver seat belt is fastened.
- The vehicle is stopped on a slope for more than 2 seconds.

- SCS is active and fault free.
- EPB is released and fault free.
- Clutch pedal is pressed (MT), or in D/R gear (AT).
- START/STOP Switch is switched ON/RUNNING.
- Sufficient brake pedal application force has been applied.

If the driver releases the brake pedal on a hill, HHC will maintain brake pressure for 1 - 2 seconds, after this period the vehicle may roll backwards.

**Note:** *HHC cannot overcome physical limitations. DO NOT solely rely on HHC.*

**Note:** *HHC is available in both forward and backward directions when pulling away on uphill slopes.*

### Hill Descent Control (HDC)



*The HDC system is only an auxiliary function. It has limitations when subject to adverse conditions such as wet or icy surfaces and steep slopes. The HDC system cannot overcome the laws of physics, always ensure that the vehicle is driven down steep slopes at low speeds.*



*Even when the HDC system is switched on, the driver must always pay close attention to the driving state of the vehicle, and take active control when necessary. In certain cases, HDC may be suspended or switched off temporarily.*



*During some driving conditions on downhill surfaces (e.g. driving down a slope at high speed or small slope, etc.), HDC is inoperative, the driver must maintain control of the vehicle at all times and use brake applications to ensure safety.*

## Starting & Driving

---

The HDC system is an auxiliary function specially designed for driving on acute downhill gradients. The system reduces the speed by applying brake force, thus assisting the driver to drive on acute downhill surfaces with low speeds.

Please **DO NOT** use this function when driving on the ordinary roads.

When the HDC is working, the brake system may generate strong vibrations or noise. It is normal during the operation of HDC.

**Note:** *During the operation of the Hill Descent Control (HDC) system, please engage a lower gear on MT models to prevent the engine stalling; on AT models, please do not move the shift lever to the "N" position or the HDC function may be deactivated.*

### HDC System On/Off

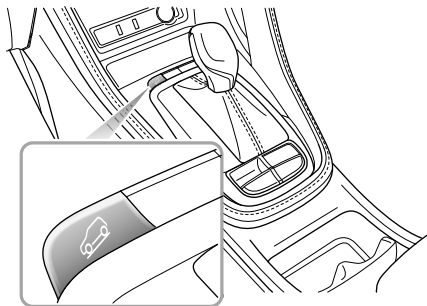

When the START/STOP Switch is switched ON/RUNNING, HDC system defaults to off. Use the switch function within the infotainment system to turn the HDC system on/off.

Normally, HDC system has four states:



## Starting & Driving

---

- 1 Standby: Press the HDC switch (ON) to set the system into standby mode, the green HDC warning lamp in the instrument pack will illuminate.
- 2 Operation whilst in Standby mode, when the vehicle is driven down an acute gradient, if the vehicle speed is low, the HDC system will automatically enter the operating state. In this case, the HDC warning lamp in the instrument pack flashes green, this may be accompanied by the working noise of the brake system. The HDC system will attempt to control the vehicle drive down the steep slope smoothly.
- 3 Temporary Deactivation: Press the accelerator or brake pedal beyond a preset limit whilst in operating mode and the HDC system will temporarily suspend operation.
- 4 Off: Press the HDC switch (OFF) to switch the system OFF; the green HDC warning lamp in the instrument pack will extinguish.

**Note:** *HDC system can work in both forward and backward directions.*

**Note:** *During HDC system operation the braking system will automatically pressurise and maintain pressure. Operation of the brake pedal during this phase may result in a 'kickback' sensation through the pedal. This is normal for HDC operation.*

### HDC ON/Malfunction Indicator Lamp

Refer to "Warning Lights and Indicators" in "Instruments and Controls" chapter.

### Anti-lock Brake System (ABS)



**ABS cannot overcome the physical limitations of stopping the car in too short a distance, cornering at too high a speed, or the danger of aquaplaning, i.e. where a layer of water prevents adequate contact between the tyres and the road surface.**

The purpose of the anti-lock braking system (ABS) is to prevent the wheels from locking while braking, thereby enabling the driver to retain steering control of the car.

## Starting & Driving

---

The fact that a car is fitted with ABS must never tempt the driver into taking risks that could affect his/her safety or that of other road users. In all cases, it remains the driver's responsibility to drive within normal safety margins, having due consideration for prevailing weather and traffic conditions.

Under normal braking conditions, ABS will not be activated. However, once the braking force exceeds the available adhesion between the tires and the road surface, thereby causing the wheels to lock, ABS will automatically come into operation. This will be recognisable by a rapid pulsation felt through the brake pedal.

### Braking in an Emergency



**DO NOT pump the brake pedal at any time; this will interrupt the operation of ABS and may increase the braking distance.**

If an emergency situation occurs, the driver should apply full braking effort even when the road surface is slippery. ABS will ensure that the wheels do not lock and that the car is brought to a halt in the shortest possible distance for the prevailing road surface conditions.

**Note: On soft surfaces such as powdery snow, sand or gravel, the braking distance produced by the ABS system may be greater than that for a non-ABS system, even improved steering would be experienced. This is because the natural action of locked wheels on soft surfaces is to build up a wedge of material in front of (or to the side of, if steering) the tyre contact patch. This effect assists the car to stop when braking or to change direction when steering.**

No matter how hard you brake, you are still able to continue steering the vehicle as normal.

#### IMPORTANT

ABS can not reliably make up for the driver's mis-operation or lack of experience.

### ABS Malfunction Indicator Lamp

Refer to "Warning Lights and Indicators" in "Instruments and Controls" section.

**Note: The normal (non-ABS) braking system remains fully operational and is not affected by partial or**

## Starting & Driving

---

*full loss of ABS. However, the braking distances may increase.*

### **Auto Hold \***



*When auto hold stops the vehicle, for reasons such as engine shut-down, releasing the seat belt or pressing the auto hold switch, the electronic parking brake is applied. It cannot be guaranteed that the vehicle will be stabilised in all cases. For example, the rear wheels are on a slippery road surface, or the vehicle incline is too great (larger than 20%). Please make sure that the vehicle is safely stabilised prior to exiting.*



*DO NOT take any extra risks when driving due to the fact the vehicle is fitted with additional convenience functions. The driver should pay full attention and observe the surroundings even if the vehicle is equipped with auto hold system.*



*The auto hold function cannot guarantee the stability of the vehicle when starting off or braking on hills especially on slippery or icy surfaces.*



*DO NOT leave the vehicle when the engine is operating and the auto hold is active.*



*Auto hold cannot guarantee the electronic parking brake operation in all cases where the power system is shut down. Please ensure the electronic parking brake is applied and the vehicle is stabilised prior to exiting the vehicle.*



*The auto hold function should be switched off during the use of automatic car washes, the electronic parking brake may suddenly apply and cause vehicle damage.*

If the vehicle is required to stop frequently for a length of time (such as traffic lights, traffic queues or stop/start), and the engine is running, the auto hold system assists in stabilising the vehicle, enabling you to remove your foot

## Starting & Driving

---

from the brake pedal when the vehicle is stationary and the Auto Hold active.

Auto hold has 3 main states:

- 1 Off: Function in Off state.
- 2 Standby: Function in Standby state. The function is active but the vehicle has not stopped. Once the vehicle has stopped, and all other conditions are met, the system will automatically select Park.
- 3 Parking: Function in Parked state. In this state the green (P) indicator on the instrument pack illuminates.

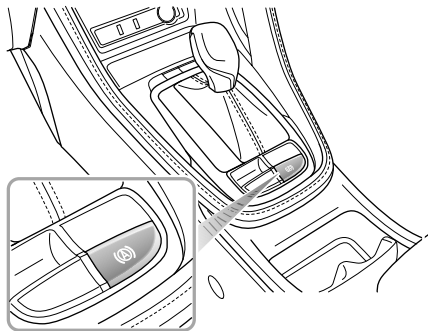

With the driver's seat belt fastened, the door closed and the engine running, press the auto hold switch to switch the auto hold function from Off to Standby state.

With the brake pedal firmly pressed and the vehicle completely stopped, the auto hold function will switch from the Standby state to the Parking state.

When the auto hold is in the Parking state, engaging forward or reverse gear and pressing the accelerator will automatically release the auto hold function.

## Starting & Driving

---

In some circumstances such as releasing the seat belt, switching off the engine or remaining static for a length of time it will result in the vehicle exiting the auto hold Parking state. At this time the electronic parking brake will remain applied and will require the driver to release it using the switch.

**Note:** *With the brake pedal pressed, operating the switch to turn the auto hold off, the system will NOT apply the parking brake.*

**Note:** *It is recommended to turn off the auto hold function when reversing into the garage.*

### Emergency Braking Hazard Warning Lights Control (HAZ)

If the vehicle is travelling in excess of 50 km/h and the driver makes an emergency braking manoeuvre, the hazard lights will be operated to indicate this to other drivers.

**Note:** *If the hazard warning lights are being operated manually, this suspends the HAZ function.*

When the emergency braking manoeuvre is exited (no severe deceleration detected) then the function will be switched off after a few seconds.

**Note:** *As the car speed drops to below 10 km/h and the system no longer flashes the brake lamps, the hazard warning lamps will illuminate automatically. Short press the hazard warning lamp switch or increase your speed to above 20 km/h for 5 s to switch off the hazard warning lamps.*

### Active Rollover Protection (ARP)



*The ARP system cannot overcome the laws of physics. It is a driver aid to assist the stability of the vehicle and under extreme conditions. It is not a guarantee that the car will not roll over.*

In cases where the vehicle has a high centre of mass, rapid or excessive dual direction lane changing may create a roll condition. ARP may use the braking system to apply certain brakes to try and correct the condition and assist in preventing rollover.

## Starting & Driving

---

**Note:** During ARP application the steering characteristics of the vehicle may be noticeably different from normal.

### Parking Brake \*



**DO NOT** drive with the parking brake applied, or apply the parking brake while the car is in motion. This could result in loss of control, prevent the ABS from functioning correctly, and may even cause damage to the rear brakes.

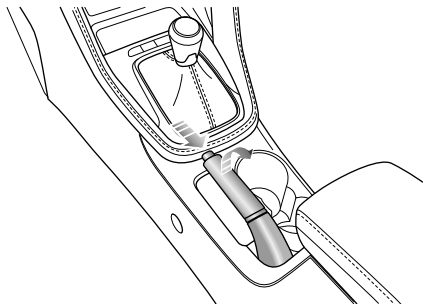

The parking brake operates on the rear wheels only. To apply the parking brake, pull the lever up. Always apply the parking brake fully whenever you park the car.

To release, pull the lever up slightly, press the button (arrowed in illustration) and fully lower the lever. When parking on a steep slope, do not rely on the parking brake alone to hold the car.

## Electronic Parking Brake (EPB) \*



***In the event of EPB malfunction where EPB release is not possible, please consult an MG Authorised Repairer in order to carry out an emergency manual release of the parking brake.***

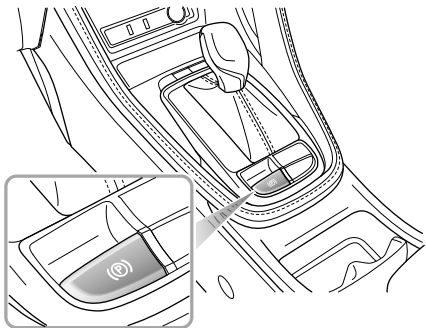

## Applying the EPB

While the vehicle is stationary, the EPB can be applied. Ensure the EPB is applied every time the vehicle is left or parked.

- Press the brake pedal, pull the EPB switch upward until the indicator in the EPB switch illuminates.
- If the indicator in the EPB switch and the indicator in the instrument pack illuminates, (P) the EPB is applied.
- If the EPB malfunction indicator lamp (P) in the instrument pack remains on, it indicates that a fault has been detected. Please contact an MG Authorised Repairer immediately.

**Note:** *An audible motor noise may be heard when applying or releasing the EPB.*

### IMPORTANT

- In the event of a flat battery or power failure, it is not possible to apply or release the EPB. In such a case, 'jump leads' shall be used for emergency engine start, please refer to "Emergency Starting" in "Emergency Information" chapter.

## Releasing the EPB

- Switch on the ignition, press the brake pedal, and press the EPB switch.
- If the indicator in the EPB switch and the indicator in the instrument pack (P) are extinguished, the EPB is released.

## Start Assist

The EPB can predict the driver's intention and automatically release the EPB.

If the driver's seat belt is fastened, the engine is started up, D or R gear is selected and the accelerator pedal is depressed for start off, the EPB will automatically release.

## Emergency Braking Function



*Inappropriate use of the EPB can lead to accidents and injuries. Do not apply the EPB for vehicle braking, unless in emergency.*



*During emergency braking using the EPB, DO NOT switch off the ignition, this could result in serious injury.*

When the car is in motion, in case of any emergency, such as the car can not be stopped by the brake pedal, it can be decelerated by pulling up and holding EPB switch.

- Pull the EPB switch upward and hold to realise the emergency braking. Continuous acoustic alarm will sound simultaneously during emergency brake.
- To cancel the emergency braking process, release the EPB switch.



## Stability Control System (SCS) and Traction Control System (TCS)

### Stability Control System (SCS)

SCS is designed to assist the driver in control of driving direction. The SCS is automatically activated after the engine is started.

When SCS detects that the vehicle is not moving in the intended direction, it will intervene by applying brake force to selected wheels or through the engine management system to prevent sliding and assist in bringing the car back to the right direction.

### Traction Control System (TCS)

The purpose of electronic traction control is to aid traction, thereby helping the driver to maintain control of the car in situations where one or both of the driving wheels are spinning (for example, if one wheel is on ice and the other on tarmac). The traction control system monitors the driving speed of each wheel individually. If spin is detected on one wheel, the system automatically brakes that wheel, transferring torque to the opposite,

non-spinning wheel. If both wheels are spinning, the system will reduce engine speed in order to regulate wheel rotation until traction is regained.

### Switching On/Off

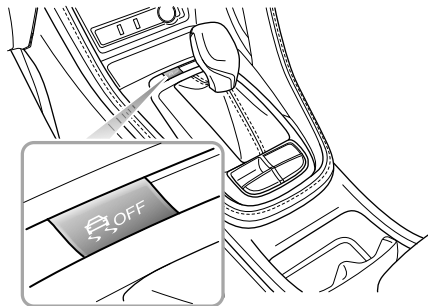

With the START/STOP Switch is switched ON/RUNNING, SCS and TCS will automatically turn on. And you can turn them off after the engine is started.

- Press SCS switch (less than 2 seconds) to turn off TCS.

## Starting & Driving

---

- Press SCS switch (longer than 2 seconds) to turn off SCS and TCS.

**Note:** *Press the SCS switch (more than 10 seconds), it will be regarded as misoperation.*

- To recover the operation of SCS and TCS, press SCS switch once again.

**Note:** *Disabling SCS and TCS will not affect the operation of ABS. Always disable TCS when driving with snow chains fitted.*

### Stability Control/Traction Control Warning

#### Lamps

Refer to "Warning Lights and Indicators" in "Instruments and Controls" section.

## Cruise Control System \*

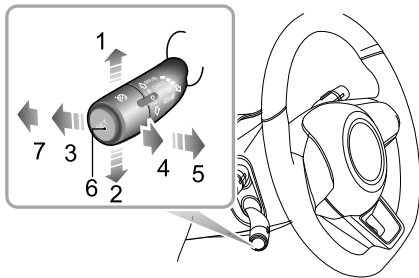

- Acceleration (1)
- Deceleration (2)
- Cruise Cancel (3)
- Cruise Standby (4)
- Cruise Resume (5)
- Cruise Set (6)
- ASL Standby (7)

Cruise control enables the driver to maintain a constant road speed without using the accelerator pedal. This is particularly useful for motorway cruising, or for any

journey where a constant speed can be maintained for a lengthy period.

### Cruise Control System Activation

Cruise control system is operated with a lever located, at the left side of the steering wheel underneath the lighting stalk switch.

With the START/STOP Switch in position ON/RUNNING, if the lever switch is in the 'ASL Standby' position (7 in figure), then the cruise control is OFF. To set the cruise control to 'Standby' pull the lever switch to 'Cruise Standby' (4 in figure), the yellow indicator lamp  in the instrument pack will illuminate indicating the system is in 'Cruise Standby' mode.

With the system in 'Standby' when the current vehicle speed is above 40km/h (the gear of vehicle with manual transmission should be at 3 or above), press the 'Cruise Set' button (6 in figure). The indicator  in the instrument pack will change to green and the cruise control will enter and activated state. The operating range is 40 - 200 km/h.

The target speed of the cruise system will be set at the current speed, and the cruise system will take effect. At

# Starting & Driving

---

this time, the cruise control system will maintain the set speed without pressing the accelerator pedal.

**Note:** *The set speed held in the cruise control memory will be cancelled when either the cruise control lever is switched to "ASL Standby" position (figure 7) or the START/STOP Switch turned off.*

## Target Cruise Speed Adjustment

When the cruise control is active, the 'target speed' can be increased or decreased:

Push the lever switch upwards (1 in figure), this will increase the speed.

Push the lever switch downwards (2 in figure), this will decrease the speed.

Release the lever switch when the desired speed is reached.

Push the lever switch upwards or downwards briefly to increase/decrease the vehicle target speed in increments of 1 km/h, then the vehicle will accelerate/decelerate to the new target speed.

Pressing the accelerator at any time will override the cruise control and allow acceleration to undertake manoeuvres

such as overtaking. Releasing the accelerator will return the vehicle to the set target speed.

## Pause/Stand By

Cruise control will be disengaged and set to 'Standby' if:

- Lever switch moved to 'Cruise Cancel' position (3 in figure).
- Brake pedal pressed.
- Auto gear lever moved to P, R or N.
- Manual gear-change made.
- Clutch pedal pressed.
- Conditions initiate SCS intervention.
- An incline causes excessive decline in speed.

## Resume

If the cruise control remains on after the disengagement, moving the lever switch to 'Cruise Resume' (5 in figure) will reinstate the target speed to the setting prior to disengagement.

### **Note:**

- **Never use the cruise control system in the reverse gear.**

- **DO NOT** use the cruise control in unsuitable conditions, such as on slippery surfaces, excessively heavy rain or in traffic conditions that **DO NOT** suit maintenance of constant speeds.
- When not in use, ensure the lever switch is in the 'ASL Standby' position (7 in figure).
- When the automatic transmission is in "Sport" mode, it is not recommended to use the cruise control system.
- During the operation of cruise control system, the actual speed may deviate from the target cruise speed to some extent due to road conditions (such as uphill, downhill, etc).
- If the actual speed is excessively lower than the target speed or SCS is activated due to the hill or road surfaces, the cruise control system may automatically revert to standby mode.
- **DO NOT** operate the switch for excessively long periods, or press multiple switches simultaneously, this may cause the system to fail. If this situation occurs, when it is safe to do so, cycle the ignition.

### Active Speed Limit (ASL) System \*

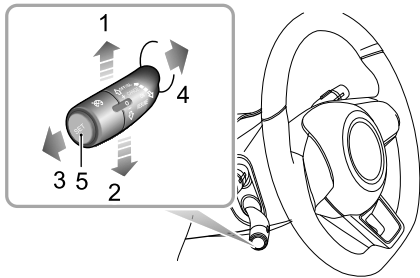

- Speed Limit Increase (1)
- Speed Limit Decrease (2)
- ASL Standby (3)
- Cruise Standby (4)
- Set (5)

The Active Speed Limit (ASL) system is designed to control the vehicle speed keeping it below a speed set by the driver.

The ASL system shares the same lever switch as the cruise control system, located to the left of the steering wheel below the indicator stalk. The switch can be toggled between both functions, however only one function can operate at any one time.

#### Activate

The desired target speed of the ASL system is displayed in the instrument information cluster. With the START/STOP Switch in position ON/RUNNING and the lever switch in "ASL Standby" (3 in figure), the ASL function is in standby mode by default, briefly moving the lever switch up/down (1,2 in figure) adjusts the target speed of the ASL. The range of target speed adjustment is 30 - 200km/h.

The target speed limit value will be increased or decreased by 5 km/h every time the lever switch is briefly moved upwards or downwards. Move the lever upwards or downwards and hold, the target speed limit value will change continuously.

Pressing the "Set" button (5 in figure) will activate the ASL system and ASL indicator lamp in the instrument pack will illuminate. When activated and vehicle speed is less than

or equal to 30 km/h, then the target speed limit value will be set at 30 km/h by default. When activated and vehicle speed is higher than 30 km/h, then the current vehicle speed will be set as the target speed limit value.

**When activated if the vehicle speed is greater than the user inputted target speed the system will begin to slow the vehicle to the inputted target.**

**When ASL is active, pressed the accelerator pedal fully (eg: overtaking) can make the vehicle speed increased. When released the pedal, vehicle speed will subject to the target speed limit value.**

### Suspend ASL

When ASL is active, to suspend the feature press the "Set" button (5 in figure) and the ASL system will exit to the standby state.

### Resume ASL

If the system has been placed in a standby state with a retained target speed the system can be reactivated to the previously stored target speed by pressing the "Set" button ( 5 in figure ) .

**Note: When ASL is suspended, if the accelerator pedal is fully depressed (eg: overtaking), the system can not be reactivated.**

### Exit ASL

Pull the lever switch to "Cruise Standby" position (4 in figure), ASL system will exit.

**Note: ASL system brakes the vehicle relied on the engine, which has limited braking capacity. ASL is not a substitute for the brakes. In case of steep slopes and other needs to brake quickly, please press the brake pedal to brake the vehicle.**

## Parking Aid System

### Ultrasonic Sensor Parking Aid



*The purpose of the parking aid is to assist the driver in reversing! The sensors may not be able to detect obstacles of certain type, e.g. narrow posts or small objects no more than a few inches wide, small objects close to the ground, objects above the tailgate and some objects with non-reflective surfaces.*



*Keep the sensors free from dirt, ice and snow. If deposits build up on the surface of the sensors, their performance may be impaired. When washing the car, avoid aiming high pressure water jets directly at the sensors from close range.*

### Rear Parking Aid

The ultrasonic sensors in the rear bumper monitor the area behind the vehicle to search for obstacles. If any obstacle is detected, the system will calculate its distance from the rear of the vehicle and communicates the message to the driver by sounding warning chimes.

### Parking Aid in Operation

When the START/STOP Switch is in the ON/RUNNING position, the rear parking aid is enabled automatically when reverse is selected, it is switched off as soon as reverse is disengaged. A short beep is given by the parking aid within 1 second after selecting reverse to indicate that the system is operating normally.

The entertainment system screen will display a silhouette image of the car showing the object distance values for the sensor.

**Note: If a longer, higher pitched sound is emitted for 3 seconds when reverse is selected this indicates a fault in the system. In this case seek assistance from your MG Authorised Repairer.**



## Starting & Driving

With the parking aid enabled, when obstacles are detected, the system will give sounds in different frequencies (there might be blind areas).

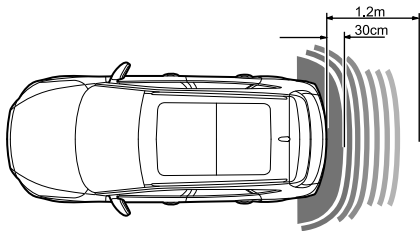

- If there is an obstacle within 1.2m range from the rear sensors, the system starts to emit a beeping sound. As the vehicle moves closer to the obstacle, the beeps are transmitted more rapidly.
- Once the obstruction is within 30cm range of the rear bumper, the beeps will merge into a continuous warning.

### Parking Camera System \*



*The purpose of the parking camera system is to assist the driver in reversing! The camera has limited field of view and cannot detect obstacles outside the field of view.*

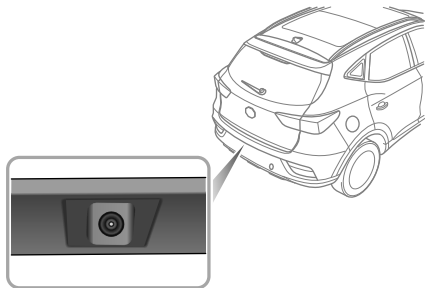

The parking camera is fitted between left and right license plate lamps. When the reverse is selected, the camera will display an image of what is directly behind the car in

the entertainment display, and the system supports the indication of distance from obstacles to vehicles.

### 360 Panoramic Imaging System \*



*The purpose of the 360 panoramic imaging system is to assist the driver during reversing! The cameras have a limited field of view and cannot detect obstructions outside the field of view.*



*Although the entertainment display can provide high-definition images around the vehicle, please still pay attention to the current actual road conditions for your driving safety.*

With the 360 panoramic imaging system working, the display interface will show a 360° panoramic image of the vehicle to facilitate the observation of the surrounding environment to make driving safer.

- When the reverse gear is selected, the system will automatically switch to the display interface of a 360° panoramic image, this will appear in the entertainment display.

## Starting & Driving



- Touch or press the 360° View button to enter into the display interface of the 360 panoramic imaging system, you are then able to touch buttons on the display to check images from different angles of view of the vehicle to provide a much safer driving environment.
- Touch the 2D or 3D button on the display to enter into the display interface of the 2D or 3D panoramic imaging system, you are then able to touch different areas around the vehicle (as displayed on the LH side of the screen) to check images from different angles of view to provide a much safer driving environment.
- Touch the Setting button in the upper right corner of the screen to open the 'Settings' interface, here you are able to switch the "when corner lights/indicators\* are active

start the 360° view" function ON/OFF. When a forward gear is selected and the left/right corner light/indicator\* is on, the 360 panoramic image system will display the corresponding left/right view.

- Touch the Setting button in the upper right corner of the screen to open the 'Settings' interface, here you are able to set the parking aid line to static, dynamic, dynamic + static, and off state.

**Note:** *When the shift lever is placed in forward gear position, in no case can 360 panoramic imaging system be enabled as long as the vehicle speed exceeds or equals to 15 km/h.*

### Rear Driver Assistance System \*

#### System Overview



*The effective recognition capabilities of the rear sensors can be limited by objects such as roadside buildings, guardrails, changes in pitch angle of the car due to heavy loading, road conditions such as bends or bumps or weather conditions such as snow and ice etc. Any of the above may trigger a false alarm.*



*The rear driver assist system may not provide adequate warning of very fast approaching vehicles or operate correctly on tight curves of 500m radius or less.*



*The rear driver assist system will not operate correctly whilst towing a trailer or caravan.*



*The system has limitations and may not be able to warn of vehicles approaching at high speeds.*



*The rear driver assistance function is only an aid, it is NOT a substitute for the attention of the driver. The driver must always remain in control, observe the surroundings and drive safely.*



*The correct operation of the rear sensors will be compromised if they are misaligned due to accident damage. This may cause the system to automatically shutdown.*



*To ensure that the radar sensors work correctly, the rear bumper should be kept free of snow and ice and must not be covered.*



*Use of non recommended materials or paint on rear bumper repairs may have a detrimental effect on the operation of the rear sensors. Please only use recommended materials.*

The rear driver assistance system includes blind spot detection (BSD), lane change assist (LCA), and rear cross traffic alert (RCTA) functions.

## Starting & Driving

The rear driver assistance modules are mounted at the rear of the vehicle on each side, they can assist in detecting vehicles behind or to the side of your vehicle.

The warning lamps to support this system are located within the LH and RH door mirror glasses, they will illuminate or flash to warn of an approaching object or car to assist you in manoeuvring the car safely.

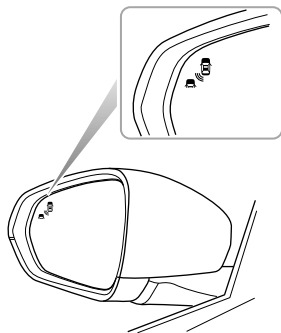

**Note:** *The radar requires calibration on new vehicles or for vehicles of where a rear detecting radar sensor has been replaced. The rear detection radar sensors possess an automatic calibration function to compensate for installation error within a certain range. When the vehicle is running, the radar will automatically enter the calibration state. During the calibration process, the system will provide limited functions, and the alarm may be inaccurate. Upon completion of the calibration, the system will resume all functions.*

### Switching the System Functions On/Off

The rear driver assist system function and sub system switches can be accessed via the infotainment screen.

Select: 'Vehicle Settings', 'Driving Assist' and 'Rear Driving Assist' (you may have to scroll left or right to access this option). Select ON/OFF to activate/deactivate the system. A warning message to alert you of your choice will be displayed in the message centre in the instrument pack.

When the vehicle is restarted, the system will keep the previously stored switch settings.

# Starting & Driving

---

## System Functions

**Note:** *The detection area, collision time threshold value and vehicle speed provided in the system function description are just for your reference.*

### Blind Spot Detection (BSD)

When the vehicle is driving forward, the system will monitor the motor vehicles located in the blind zones of the left and right exterior mirrors. When the conditions for activating the blind spot detection function are met, the warning lamps in the corresponding mirror will illuminate. Subsequent operation of the relevant indicator will cause the warning lamp in the mirror to flash to remind the driver of an approaching vehicle.

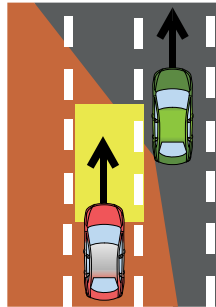

The conditions for activating the blind spot detection function include:

- 1 Rear driver assistance system is in the ON state and no faults are present in the system.
- 2 Blind spot detection (BSD) function is enabled.
- 3 The vehicle speed is above 20mph (30km/h).
- 4 There are motor vehicles in the blind zone of the vehicle. The system monitors both the left and right of the vehicle, the monitored areas are 2m ahead , 7m

# Starting & Driving

---

behind the rear of the vehicle, and 4.7m from the side of the vehicle.

**Note:** *The warning lamps will not illuminate whilst you are overtaking another vehicle and your speed is greater than that of the vehicle you are passing, even though it is in the blind zone.*

## Lane Change Assist (LCA)

When the vehicle is driving forward, the system will monitor the motor vehicles approaching rapidly in the adjacent lanes. When the indicators are activated, and the conditions for activating the lane change assist function are met, the system will flash the warning lamp within the respective mirror to warn the driver of an approaching vehicle. This aims to help avoid collisions when changing lanes.

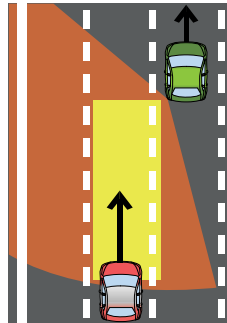

# Starting & Driving

---

The conditions for activating the lane change assist function include:

- 1 Rear driver assistance system is in the ON state and no faults are present in the system.
- 2 Lane change assist (LCA) function is enabled.
- 3 The vehicle speed is above 20mph (30km/h).
- 4 The speed of the approaching vehicle is higher than the speed of your vehicle.
- 5 The approaching vehicle enters the detection area of the LCA, the monitored areas are 7 - 70m behind your vehicle and 4.7 m to the side of your vehicle.
- 6 The approaching vehicle is likely to have a collision with your vehicle within 3.5 seconds.

## Rear Cross Traffic Alert (RCTA)

When the vehicle is reversing, the system will monitor vehicles approaching from the left and right rear. When the conditions for activating RCTA function are met, the warning lamps in the mirrors on the corresponding side will illuminate, simultaneously a warning triangle icon for the corresponding side will be displayed in the infotainment screen to alert the driver to the situation.

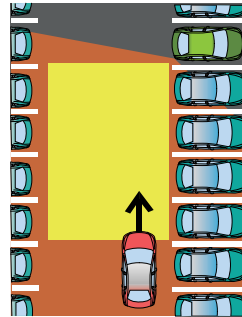



The conditions for activating the rear cross traffic alert function include:

- 1 Rear driver assistance system is in the ON state and no faults are present in the system.
- 2 Rear cross traffic alert (RCTA) function is enabled.
- 3 The vehicle is in Reverse gear.
- 4 The vehicle speed is less than 5mph (9km/h).
- 5 The speed of the vehicle being monitored is above 5mph (9km/h).
- 6 The motor vehicle drives across the system detection areas. The areas monitored to the left and right of the vehicle are 5m behind the rear of the vehicle, and 25m from the side.
- 7 The approaching vehicle is likely to have a collision with your vehicle within 2.5 seconds.

### Tyre Pressure Monitoring System (TPMS)



*TPMS cannot replace routine maintenance and check of the tyre condition or pressure.*



*If radio transmission devices such as mobile telephones or wireless headsets are used in close proximity to the vehicle it may result in interference with the TPMS and could register as a fault.*

**Note:** *TPMS only gives the driver a warning when the tyre pressure is low, it will not inflate the tyre.*

TPMS uses pressure sensors built into tyre valves to continuously monitor pressure and transmits signal to ECU inside the vehicle using RF signals. If it deduces that the pressure of that tyre has fallen below the predefined limit of the system, the warning light on the instrument pack will illuminate (always yellow). For more information, please refer to 'Instrument Pack' in 'Instruments and Controls' section. Check your tyres at the earliest opportunity and

reinflate to the correct pressure. Please refer to 'Tyre Pressure (Cold)' in 'Technical Data' section.

### System Malfunction



This system is self-monitoring, if a malfunction is detected, the TPMS warning lamp (yellow) on the instrument pack will flash for 90 seconds first and then illuminate.

**Note:** *When a puncture is detected, the system will require some time to analyse information prior to illuminating the warning lamp.*

Under certain conditions the warning light may illuminate when a fault is not present, these conditions include:

- A non recommended tyre fitted (including spare tyre).
- Rough terrain driving for excessive periods.
- Bending or mountain type terrain driving for excessive periods.
- TPMS will not respond immediately if a tyre 'blows out'.

### **TPMS Self-learning**

The TPMS system is a 'self learning' system, after resetting tyre pressures it will be necessary to allow the system to go through a self learning process. This is done by driving the car, during this process the system is suspended and the data displayed may not be correct. If sensors or receiver module are replaced the system requires programming, consult an MG Authorised Repairer. If the wheels are swapped or rotated the system requires reprogramming to learn the new transmitter positions, consult an MG Authorised Repairer.

# Starting & Driving

## Loading



**DO NOT exceed the gross vehicle weight or the allowable load of front and rear axle when loading, otherwise it may cause vehicle damage or personal injury and death!**

## Trunk Loading



**Ensure that the rear seats are securely latched in the upright position when loads are carried in the load space behind the seats.**



**If the tailgate can not be closed due to cargo loaded, be sure to close all windows during driving, select the face distribution mode of the air conditioning, and set the blower to maximum speed, so as to decrease vehicle exhausts into the vehicle.**

When luggage carried in the trunk, always ensure heavy items are placed as low and as far forward as possible, so as to avoid the cargo shift in the event of an accident or sudden stop.

Driving carefully, and avoid emergency brakes or hard acceleration when carrying large or heavy cargos.

Driving with tailgate open is very dangerous. If loading with the tailgate open is unavoidable, the cargo and the tailgate must be well fixed, and take appropriate measures to prevent vehicle exhausts entering.

### IMPORTANT

Traffic regulations must be observed when loading cargos; if the cargo extrudes the load space, appropriate warning measures should be taken to draw attention of other drivers.

## Internal Loading



**DO NOT carry unsecured equipment, tools or luggage that could move, causing personal injury in the event of an accident, or emergency brakes or hard acceleration.**



**DO NOT obstruct driver and passengers to keep right sitting posture and observation if loading in the vehicle.**

Folding the rear seats can increase luggage space, refer to "Rear Seats" described in the "Seats and Restraints" section.

When cargo is loaded in the vehicle, place it at a position as low as possible and ensure that it is tightly secured, so as to avoid personal injury caused by cargo movement when traffic accidents or emergency brakes occur. If the cargo has to be put on a seat, no individual is allowed to sit on that seat.



## **Emergency Information**

---

*214 Hazard Warning Devices*

*215 Emergency Starting*

*217 Vehicle Recovery*

*222 Wheel Replacement*

*226 Fuse Replacement*

*233 Bulb Replacement*

# Emergency Information

---

## Hazard Warning Devices

### Hazard Warning Lights

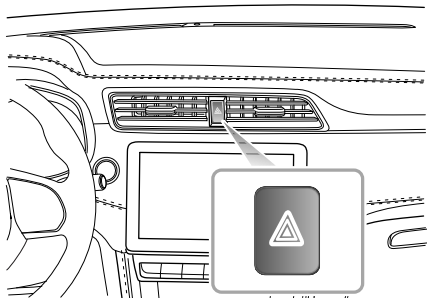

**Note:** Before you stop or slow the car in an emergency, always press the hazard warning switch. All the direction indicators will flash together to warn other road users when your car is causing an obstruction or is in a hazardous situation. Remember to switch off before driving away.

## Warning Triangle

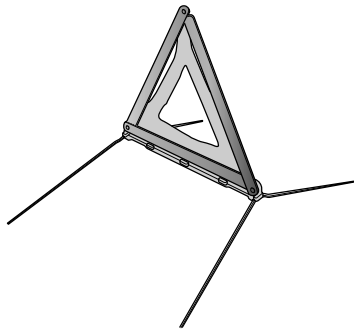

The warning triangle supplied with your car is stowed in the loadspace.

If you have to stop your car on the road in an emergency, you must place a warning triangle approximately 50 - 150 metres behind the car, if possible, to warn other road users of your position.



# Emergency Information

## Emergency Starting

### Using Booster Cables

**!** NEVER attempt to start the engine by pushing or towing.

**!** Make sure that both batteries are of the same rated voltage (12 volts), and that the booster cables are approved for use with 12 volt car batteries.

**!** Ensure sparks and naked flames are kept well away from the front compartment.

Using booster cables (jump leads) from a donor battery, or a battery fitted to a donor vehicle, is the only approved method of powering a car with a flat battery.

If the battery from a donor vehicle is to be used, make sure that the vehicles are parked so that the two batteries are adjacent to one another and that both the vehicles do not touch.

## Starting the Car



Ensure that each booster cable connection is securely made. There must be no risk of the clips accidentally slipping from the battery terminals (as a result of engine vibration, for example), this could cause sparking, which could lead to fire or explosion.

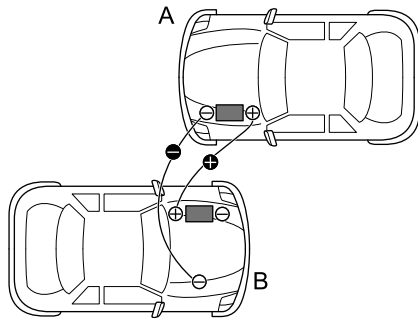

## Emergency Information

Ensure the START/STOP switch is turned off and switch off ALL electrical equipment of BOTH vehicles, then follow the instructions below:

- 1 Connect the RED booster cable between the positive (+) terminals of both batteries. Connect the BLACK booster cable from the negative (-) terminal of the donor battery (A) to a good earth point (an engine mounting or other unpainted surface, for example), as far away from the battery as possible and well away from fuel and brake lines on the disabled vehicle (B).
- 2 Check that the cables are clear of moving parts of both engines, then start the engine of the donor vehicle and allow it to idle for a few minutes.
- 3 Now start the engine of the vehicle with the discharged battery (DO NOT crank the engine for more than 10 seconds). If the disabled vehicle will not start after several attempts, it may need to be repaired. Please contact the MG Authorised Repairer.
- 4 After both the vehicles have normally started, allow the engines to idle for more than 2 minutes before shutting down the engine of the donor vehicle and disconnecting the booster cables.

### Important

NEVER turn on any electrical equipment on the started vehicle before removing the booster cables.

- 5 Disconnecting the booster cables must be an exact reversal of the procedure used to connect them, i.e. disconnect the BLACK cable from the earth point on the disabled vehicle FIRST.

# Emergency Information

## Vehicle Recovery

### Towing for Recovery

#### Towing Eye



**DO NOT use a tow rope that is twisted - any untwisting force could unscrew the towing eye.**

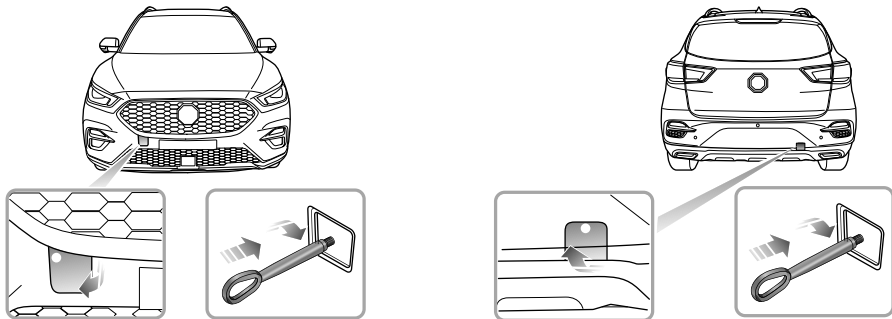

## Emergency Information

---

Your car is equipped with a removable towing hook, that can be used at the front or the rear of your vehicle. The towing hook is stored in the tool kit beneath the loadspace floor when not in use.

To fit the towing hook, first press one end of the small cover plate (the white dot in the figure above), then open the small cover plate after the other end is lifted, then screw the towing hook through the small hole into the threaded hole on the bumper beam (as shown in the figure). Ensure the towing eye is fully tightened.

**Note:** *The towing eye cover may be secured to the bumper by a plastic cord.*

Both towing points are intended for use by qualified recovery specialists to assist in the recovery of your car when a breakdown or accident occur, such as pulling your vehicle onto the trailer, etc. They are not designed for towing other vehicles, and must NEVER be used to tow a trailer or caravan. The car can be towed by using a soft rope, but a hard rod is preferred.

### Towing for Recovery



***If, due to an electrical fault, potential safety hazards may exist, it is not allowed to put the START/STOP Switch in the ON/RUNNING position.***



***When towing, DO NOT suddenly accelerate or brake suddenly, this can cause accidents.***



***The towing speed of a vehicle must not exceed 30 km/h, the towing distance shall not exceed 50 km.***

### Suspended Towing

If your car needs to be towed, most qualified recovery specialists will use wheel lift equipment to suspend the front wheels, while the rear wheels remain on the ground. Ensure the parking brake is released, the hazard warning lamps are activated and no passengers are left in the vehicle.

## Emergency Information

---

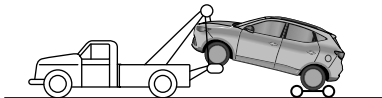
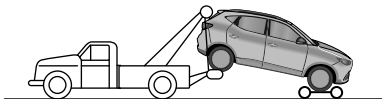
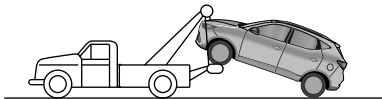

### *Four-Wheel Touchdown Towing*

**!** **DO NOT** tow the vehicle equipped with **Continuously Variable Automatic Transmission (CVT)** with four wheels on the ground. The vehicle can only be towed by suspension or transported on a trailer, otherwise the transmission may be damaged.

If vehicle is towed with the four wheels on the ground, observe the following precautions:

- 1 Switch the **START/STOP** Switch to the **ON/RUNNING** position to enable the brake lights, wipers and direction indicators to be operated if necessary. If, due to an electrical fault, it is considered unsafe to switch the **START/STOP** Switch on, the car will need to be recovered on a trailer.
- 2 Place the shift lever in **N** position (manual transmission), or in **N** position (automatic transmission).
- 3 Release the parking brake.
- 4 Turn on the hazard warning lamps.

## Emergency Information

- 5 If the transmission is damaged or has a lack of lubricating oil, **DO NOT** tow the vehicle with four wheels on the ground.
- 6 **DO NOT** tow backward with front wheels (drive wheels) on the ground.

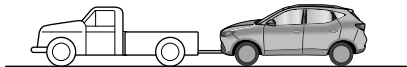

Without the engine running, greater effort will be required to operate the brake pedal and turn the steering wheel. Longer stopping distances will also be experienced.

### Transporter or Trailer with Rope

If your car is to be transported on the back of a trailer or transporter, it must be secured as illustrated:

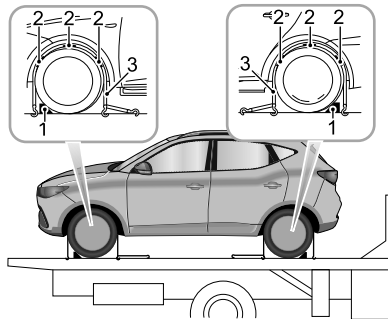

- 1 Position the car on the trailer, apply the parking brake, and place the shift lever in N position (manual transmission), or in P position (automatic transmission).

## Emergency Information

---

- 2 Place the wheel chock (1) as shown in the figure, then place the anti slip rubber pad (2) around the circumference of the tyre.
- 3 Fit the lashing straps (3) around the wheels and secure to the trailer. Tighten the straps until the car is securely held.

# Emergency Information

## Wheel Replacement

### Spare Wheel and Toolbox

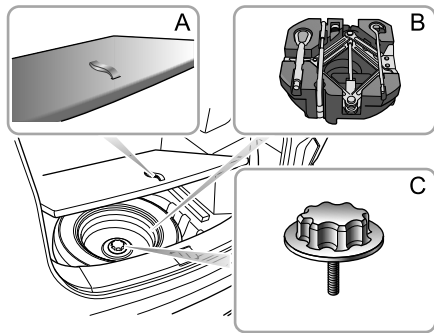

### Spare Wheel and Tool Removal

- 1 Lift the carpet in the trunk with the lifting strap (A).
- 2 Remove the tool tray (B).
- 3 Unscrew the spare wheel retaining nut (C) and lift the spare wheel from the trunk.

### Spare wheel replacement tool

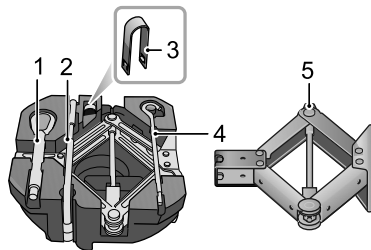

- 1 Towing hook
- 2 Wheel bolt spanner
- 3 Wheel bolt cap removal tool
- 4 Jack handle
- 5 Jack

### Changing a Wheel

If you need to change the wheel during the journey, choose a safe place to stop away from the main thoroughfare if



# Emergency Information

possible. Always ask your passengers to get out of the vehicle and wait in a safe area away from other traffic.

Switch on hazard warning lamps. If the conditions permit, place a warning triangle which is approximately 50 to 150 meters away behind the vehicle to warn other vehicles.

Before changing a wheel, ensure the front wheels are in the straight ahead position, Apply the parking brake, and place the shift lever in N position (manual transmission), or in N position (automatic transmission).

Observe the following precautions:

- Ensure the jack is positioned on firm, level ground.
- If vehicles have to be parked on the hill, wedge-shaped bumpers shall be placed before/after the other three wheels to avoid the vehicle moving.

## Positioning the Jack



**NEVER work beneath the vehicle with the jack as the only means of support. The jack is designed for wheel changing only!**



**NEVER jack the vehicle using any jacking points other than the designated points shown. Otherwise serious damage to the vehicle could result.**

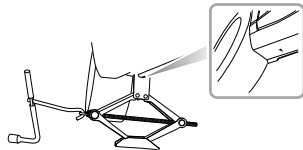
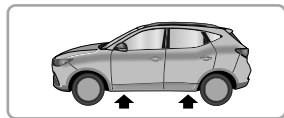

Position the jack on firm level ground under the jacking point nearest the wheel to be removed. Make sure the rectangle slot of the jack must support the vehicle body revers (see the figure).

## Emergency Information

---

Turning the jack screw rod handle by hand, raise the jack until the jack head fits snugly on vehicle body revers. Ensure that the base of the jack is in full contact with the ground.

### Replacing with Spare Wheel



**Check the pressure of the spare wheel to avoid flat tyre as it is not used for a long time. Always check tyre pressures after changing a wheel.**



**After replacing the wheel, you must tighten the wheel bolts to the specified torque (120 ~ 130Nm).**

- 1 Before raising the vehicle, use the vehicle tool to remove each wheel bolt cap. Use the wheel spanner to slacken the bolt half a turn anti-clockwise.
- 2 Turn the jack handle in a clockwise direction until the tyre is clear of the ground.
- 3 Remove the wheel bolts and place them in the toolbox to prevent them from being lost. Make sure

the vehicle is steady and there is no risk of slip or movement before removing wheel bolts.

- 4 Remove wheels.

**Note: Avoid placing wheels face down on the ground - the surface may be scratched.**

- 5 Fit the spare wheel and tighten the wheel bolts until the wheel is seated firmly against the hub.
- 6 Lower the vehicle and remove the jack, then FULLY tighten the wheel bolts in a diagonal sequence.
- 7 Finally, stow the tools back into the tool tray, and put the replaced wheel into the well under the trunk floor (with the wheel rim facing down).

**Note: DO NOT stand on the handle of the wheel bolt spanner or use extension tube on the handle of the spanner.**

**Note: When replacing the wheel, please fully tighten the bolts in the diagonal sequence in 2 times.**

**Note: Contact an MG Authorised Repairer to replace with a new tyre urgently.**

## Emergency Information

---

### Spacesaver Spare Wheel



*Only one spacesaver spare wheel can be used at any one time, otherwise the operational performance and brake performance may be reduced, thereby leading to accident or injury to yourself and others.*



*When driving on icy or slippery surfaces it is advised to fit the spacesaver wheel to the rear of the vehicle to maintain adequate stability. This may mean swapping a front wheel with a rear wheel.*



*Snow chains can not be used on the spacesaver spare wheel, this can cause damage to the car and snow chain.*

*car wash may conflict with the wheel/tyre and cause damage.*

When the spacesaver spare wheel is fitted, the vehicle speed should not exceed 80 km/h. Please have the full-scale tyre repaired and replace the spare wheel as soon as possible. This will extend the life span of the spare wheel for other emergencies.

**Note:** *DO NOT use an automatic car wash when the spacesaver wheel is fitted, the guide rails of the*

# Emergency Information

## Fuse Replacement

### Fuse

Fuses are simple circuit breakers which protect the vehicle electrical equipment by preventing the electrical circuits from being overloaded. A blown fuse indicates that the item of electrical equipment it protects stops working.

Check a suspect fuse by removing it from the fuse box and looking for a break in the wire inside the fuse.

It is recommended to have spare fuses in the vehicle, which can be obtained from a local MG Authorised Repairer.

#### IMPORTANT

- NEVER attempt to repair a blown fuse. ALWAYS replace a fuse with one of the same rating.
- If a replaced fuse fails immediately, please contact an MG Authorised Repairer as soon as possible.

### Fuse Box

There are two fuse boxes in the vehicle :

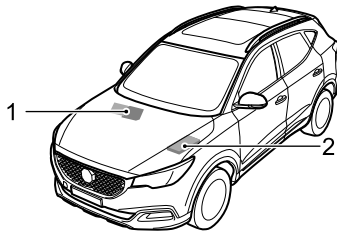

- 1 Passenger Compartment Fuse Box ( below the glove box at the front passenger side ) .
- 2 Front Compartment Fuse Box ( at the left side of the Front Bay ) .

# Emergency Information

## Passenger Compartment Fuse Box

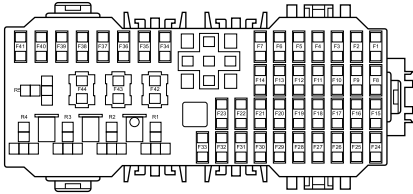

### Check or Replace a Fuse

- 1 Switch off the vehicle power system and all electrical equipment, disconnect the battery negative cable.
- 2 Remove the closing panel below the glove box to gain access to the fuse box.

- 3 Press the fuse extraction tool onto the fuse head and pull to remove the fuse. A blown fuse can be recognised by a break in the wire.

- 4 Replace the blown fuse with a same rating.

### Fuse Specification

NO.	Specs	Function
F1	15A	Front Washer Relay, Rear Washer Relay
F2	10A	Diagnostic Socket
F3	5A	PRND Display
F4	10A	Front Left Seat Heating Relay
F5	10A	Airbag ECU (SDM)
F6	5A	Gateway
F7	30A	Driver Seat Adjust Switch
F8-F11	-	-

## Emergency Information

NO.	Specs	Function
F12	5A	Left Rear Driving Assistance Radar
F13–F14	-	-
F15	15A	Front Power Socket
F16	5A	Front Courtesy Lamp, Outside Mirror and Master Light Height Adjust Switch, Top USB, Left Headlamp Assembly, Right Headlamp Assembly
F17	5A	Rear USB
F18	5A	EPB Switch
F19	5A	Outside Mirror and Master Light Height Adjust Switch, Rain Light Sensor, Information Faceplate
F20	10A	Front Right Seat Heating Relay

NO.	Specs	Function
F21	10A	360° View Module, Passenger Compartment Fuse F12
F22	10A	Exterior Mirrors Heating Element
F23	25A	Rear Windscreen Heating Element
F24	20A	Front Central Display, Front Infotainment Control Module
F25	10A	Electronic Temperature Controller
F26	5A	Instrument Pack
F27	15A	Transmission Control Module-AT/CVT
F28	30A	Sunroof
F29	30A	Sunroof
F30	5A	TBOX

# Emergency Information

NO.	Specs	Function
F31	5A	Tyre Pressure Monitoring System
F32	10A	Electronic Steering Column Lock
F33–F41	-	-
F42	25A	Stability Control Module(Valve)-MT
F42	40A	Stability Control Module(Valve)-AT/CVT
F43	30A	Passenger Window lift Switch, Rear Left Window Lift Switch
F44	30A	Driver Door Switch Pack, Driver Window Lifter, Rear Right Window Lift Switch

## Front Compartment Fuse Box

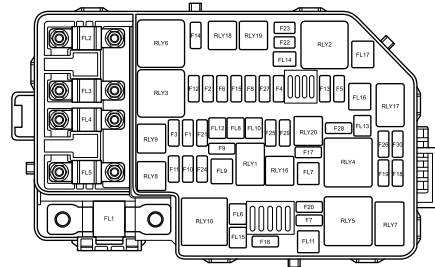

5

# Emergency Information

## Check or Replace a Fuse

- 1 Switch off the vehicle power system and all electrical equipment, disconnect the battery negative cable.
- 2 Press the locating clips to remove the fuse box lid.
- 3 Press the fuse extraction tool onto the fuse head and pull to remove the fuse. A blown fuse can be recognized by a break in the wire.
- 4 Replace the fuse with a same rating.

## Fuse Specification

NO.	Specs	Function
FL1	150A	Alternator
FL2	80A	Electric Power Steering Module
FL3	40A	Cooling Fan Relay Pack
FL4	80A	Windscreen/Mirror Heating Relay, Passenger Compartment FuseF18、 F19、 F20、 F21、 F42、 F43、 F44

NO.	Specs	Function
FL5	80A	KLR Relay, Passenger Compartment FuseF24、 F25、 F26、 F27、 F28、 F29、 F30、 F31、 F32
FL6	-	-
FL7	40A	Electronic Temperature Controller, Blower
FL8	20A	Body Control Module
FL9	40A	Stability Control Module(Pump)
FL10	-	-
FL11	-	-
FL12	-	-
FL13	30A	Starter Relay
FL14	-	-
FL15	30A	EVP Relay



## Emergency Information

NO.	Specs	Function
FL16	-	-
FL17	-	-
F1	10A	Right Headlamp Assembly
F2	15A	Downstream Lambda Sensor, Upstream Lambda Sensor, Positive Temperature Coefficient(1.5L), Canister Purge Valve(1.3T), Purge Washer Pump(1.3T)
F3	10A	Left Headlamp Assembly
F4	10A	Compressor Relay
F5	5A	Engine Control Module
F6	10A	Fuel Injector
F7	30A	Front Wiper Enable Relay, Front Wiper High/Low Speed Relay

NO.	Specs	Function
F8	5A	Cooling Fan Relay Pack, Brake Pedal Switch, Fuel Pump Relay, AC Pressure Switch, Canister Stop Valve(1.3T), EVP Relay(1.5L), Compressor Relay, Clutch Pedal Bottom Switch
F9	20A	Fuel Pump Relay
F10	10A	Right Headlamp Assembly
F11	10A	Left Headlamp Assembly
F12	30A	Ignition Coil, Engine Control Module
F13	15A	Horn Relay
F14	-	-
F15	10A	Intake Variable Camshaft Timing, Exhaust Variable Camshaft Timing, Canister Purge Valve(1.5L), Oil Control Valve(1.3T)

## Emergency Information

NO.	Specs	Function
F16	15A	Rear Wiper Relay
F17	10A	Front Left Fog Lamp Relay
F18	5A	Sensing Diagnostic Module
F19	5A	Reverse Lamp Switch, Shifter Mechanism, Front Detection Radar, Front View Control Module
F20	5A	Engine Control Module
F21	25A	Body Control Module
F22	-	-
F23	-	-
F24	-	-
F25	30A	Body Control Module
F26	-	-
F27	15A	Body Control Module
F28	10A	Front Right Fog Lamp Relay

NO.	Specs	Function
F29	-	-
F30	5A	Engine Control Module, Transmission Control Module-CVT

# Emergency Information

---

## Bulb Replacement

### Bulb Specification

Lamp Bulb	Specifications
Headlamp High/Low Beam	LED
Front Direction Indicators	LED
Daytime Running Lamps	LED
Front Side Light	LED
Front Fog Lamps *	H8 35W
Reverse Lamps	W16W 16W
Rear Direction Indicators	WY16W 16W

Lamp Bulb	Specifications
Rear Side Light	LED
Stop Lamps	LED
License Plate Lamps	W5W 5W
Rear Fog Lamps	LED
High Mounted Stop Lamp	LED
Interior Lamp	W5W 5W
Load Space Lamp	C10W 10W

# Emergency Information

---

## Bulb Replacement

Before replacing any bulb, turn off the lighting switch to avoid any possibility of a short circuit.

**Note: MG only recommends replacement bulbs that completely meet the manufacturers specifications.**

Take care NOT to touch the glass with your fingers; always use a cloth to handle the bulb. If necessary, clean the glass with methylated spirits to remove fingerprints.

If in doubt, when replacing bulbs, contact an MG Authorised Repairer.

For replacement of other bulbs not listed please consult an MG Authorised Repairer.

## Interior Lamp Bulb Renewal

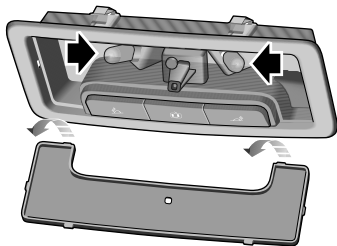

- 1 Lightly prize up lampshade from the lamp assembly with flat-blade screwdriver.
- 2 Pull the bulb out of the bulb holder.

The bulb refit procedure is in reverse order with the bulb removal procedure.

# Emergency Information

---

## Load Space Lamp Bulb Renewal

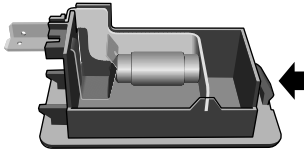

- 1 Insert a suitable tool or small flat bladed screwdriver into the indent on one of the narrow sides (as arrowed in figure) of the lens and carefully remove the unit from its location.
- 2 Push while rotating the bulb to remove it.

The bulb refit procedure is in reverse order with the bulb removal procedure.



## **Maintenance**

---

238 *Maintenance*

242 *Bonnet*

244 *Engine Compartment*

246 *Engine*

250 *Cooling System*

252 *Brake*

254 *Battery*

256 *Washers*

258 *Wipers*

261 *Tyres*

267 *Cleaning and Vehicle Care*

# Maintenance

---

## Maintenance

### Routine Maintenance

The safety, reliability and performance of your car will depend partly on how well it is maintained. You must ensure that maintenance is carried out when required and according to the information contained in the 'Service Schedule'.

### Servicing

For next service information, please refer to "Message Centre" in "Instruments and Controls" chapter or information related to entertainment system. After the completion of each service, the next service display will be reset by your MG Authorised Repairer.

**Note: If a service is not carried out (or the display is not reset by the local MG Authorised Repairer after service), the service display cannot provide correct information.**

### Service History

Ensure your local MG Authorised Repairer fills in the Service Records after each service.

### Brake Fluid Replacement

Replace the brake fluid according to the information contained in the "Service Schedule".

**Note: Brake fluid replacement will be an additional cost.**

### Coolant Replacement

Replace the engine coolant (mixed solution of antifreeze and water) according to the information contained in the "Service Schedule".

**Note: Coolant replacement will be an additional cost.**

### Emission Control

Your car is fitted with emission and evaporative control equipment designed to meet specific territorial and legal requirements. Incorrect engine settings may adversely affect exhaust emissions, engine performance and fuel



consumption, as well as causing high temperatures, which could result in damage to the catalytic converters and engine.

## IMPORTANT

You should be aware that unauthorised replacement, modification or tampering with this equipment by an owner or motor vehicle repairer could result in the manufacturer's warranty being deemed as invalid. In addition, engine settings must not be tampered with.

### Owner Maintenance



***Any significant or sudden drop in fluid levels, or uneven tyre wear, should be reported without delay. For further information, refer to an MG Authorised Repairer.***

In addition to the routine services referred to previously, a number of simple checks must be carried out more frequently. You can carry out these checks yourself and advice is given on the pages that follow.

#### Daily Checks

- Operation of lights, horn, direction indicators, wipers, washers and warning lights.
- Operation of seat belts and brakes.
- Look for fluid deposits underneath the car that might indicate a leak.
- Check tyre appearance.

#### Weekly Check

- Engine oil level.
- Coolant level.
- Brake fluid level.
- Windscreen washer fluid level.
- Operate air conditioning.

***Note: The engine oil level should be checked more frequently if the car is driven for prolonged periods at high speeds.***

#### Special Operating Conditions

If your car is frequently used in dusty conditions, or operated in extreme climates where sub-zero or very high ambient temperatures are normal, more frequent attention may need to be paid to servicing requirements. You need to carry out special maintenance operations

# Maintenance

---

(refer to Service Portfolio or contact your MG Authorised Repairer).

## Safety in the Garage



***Cooling fans may commence operating after the engine is switched off, and continue operating for a number of minutes. Keep clear of all fans while working in the engine compartment.***

If you need to carry out maintenance, observe the following safety precautions at all times:

- Keep your hands and clothing away from drive belts and pulleys.
- If the car has been driven recently, **DO NOT TOUCH** exhaust and cooling system components until the engine has cooled.
- **DO NOT TOUCH** electrical leads or components while the engine is running, or with the ignition switch on.
- **NEVER** leave the engine running in an unventilated area - exhaust gases are poisonous and extremely dangerous.

- **DO NOT** work underneath the car with a wheel changing jack as the only means of support.
- Ensure that sparks and naked lights are far away from the engine compartment.
- Wear protective clothing and work gloves.
- Remove watches and jewelry before working in the engine compartment.
- **DO NOT** allow tools or metal parts of the car to make contact with the battery leads or terminals.

## Toxic Liquid

Fluids used in motor vehicles are poisonous and should not be consumed or brought into contact with open wounds. These include: battery acid, coolant, brake fluid, power steering fluid, fuel, engine oil and windscreen washer additives.

For your own safety, **ALWAYS** read and observe all instructions printed on labels and containers.

## Used Engine Oil

Prolonged contact with engine oil may cause serious skin disorders, including dermatitis and cancer of the skin. Wash thoroughly after contact. Used engine oil should

## Maintenance

---

be disposed of correctly. Incorrect disposal can cause a threat to the environment.

# Maintenance

## Bonnet

### Opening the Bonnet



**DO NOT drive when the bonnet is not closed or retained only by the safety catch.**

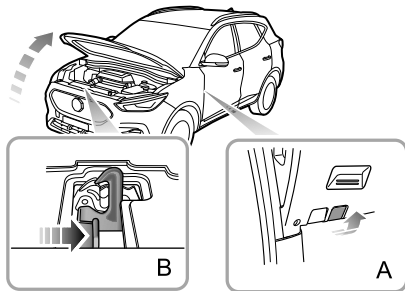

- 1 From the inside of the vehicle, pull the bonnet release handle (Figure A).
- 2 Move the safety catch release handle on the bonnet lock assembly in the direction of the arrow (Figure B) to release the bonnet safety catch.
- 3 Raise the bonnet and hold it up with the support rod firmly.

### Closing the Bonnet

Support the bonnet by one hand, release the support rod using the other hand, and place it firmly into the support rod base. Then hold the bonnet using both hands and lower it, allowing it to drop for the last 20 cm ~ 30 cm to fully close the bonnet.

By attempting to lift the front edge of the bonnet, check if the lock is fully engaged after closing the bonnet. If it is not fully engaged, you must repeat the operation.

### Bonnet Open Warning

If the bonnet is not fully engaged, when the vehicle power system is in the ON/RUNNING position, the corresponding alarm icon will be displayed in the

information message centre of the instrument pack. If it is detected that the bonnet is not fully engaged whilst driving, an audible warning will sound.

## IMPORTANT

- For safety reasons, the bonnet should be fully latched and secure when driving. Therefore every time the bonnet is opened, you must check after closing that the bonnet is securely latched, e.g. the bonnet edge is flush with the body of the car.
- You should stop the car immediately when safety permits and close the bonnet if it is not closed fully when driving.
- Ensure the bonnet is supported manually when removing the bonnet support rod, failure to support the panel will result in the panel falling down causing injury or vehicle damage.
- Beware of injury to hands while fully closing the bonnet with a downward force.

# Maintenance

---

## Engine Compartment

### 1.5L Engine Compartment



*While working in the engine compartment, always observe the safety precautions listed under 'Safety in the Garage', refer to 'Maintenance' in 'Maintenance' section.*

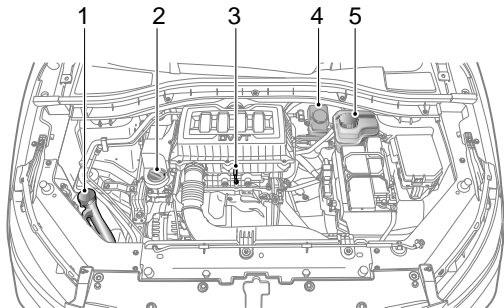

- 1 Washer fluid reservoir (blue cap)
- 2 Engine oil filler cap (black cap)
- 3 Engine oil dipstick (yellow)
- 4 Brake fluid reservoir (yellow cap)
- 5 Coolant reservoir (black cap)

# Maintenance

## I.3L Turbocharged Engine Compartment



*While working in the engine compartment, always observe the safety precautions listed under 'Safety in the Garage', refer to 'Maintenance' in 'Maintenance' section.*

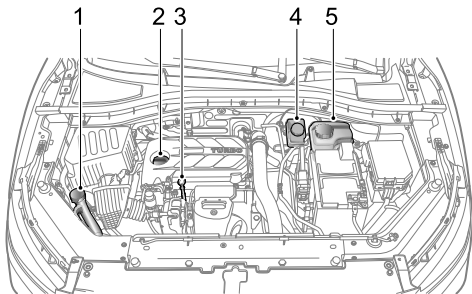

- 1 Washer fluid reservoir (blue cap)
- 2 Engine oil filler cap (black cap)
- 3 Engine oil dipstick (yellow)
- 4 Brake fluid reservoir (yellow cap)
- 5 Coolant reservoir (black cap)

## Engine

### 1.3L Turbocharged Engine Oil

#### API, ILSAC and ACEA Classification of Engine Oils

The American Petroleum Institute ( API ) 、 International Lubricants Standardization and Approval Committee ( ILSAC ) 、 The European Automobile Manufacturers Association (ACEA) classifies the engine oils based on their performance and quality. To ensure the best performance of the vehicle, please use the SN/GF-5 5W-30 or C3 5W-30 engine oil recommended by the manufacturer.

Choose the oil viscosity according to the ambient temperature. If the temperature change is minimal, continue using the oil of original viscosity.

If you are using your vehicle in an extreme cold region, we advise you to use the SAE 0W-30 engine oil recommended by the manufacturer.

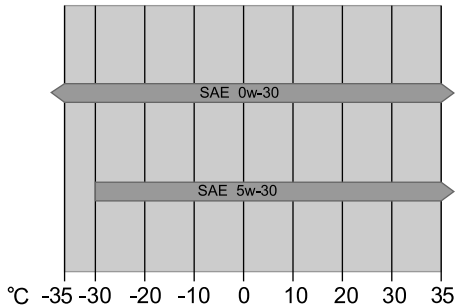



## 1.5L Engine Oil

### ACEA Classification of Engine Oils

The European Automobile Manufacturers Association (ACEA) classifies the engine oils based on their performance and quality. To ensure the best performance of the vehicle, please use the ACEA A5/B5 or C5 engine oil recommended by the manufacturer.

Choose the oil viscosity according to the ambient temperature. If the temperature change is minimal, continue using the oil of original viscosity.

In normal temperature, we advise you to use the SAE 5W-30 or 0W-20 engine oil recommended by the manufacturer.

If you are using your vehicle in an extreme cold region, we advise you to use the SAE 0W-20 or 0W-30 engine oil recommended by the manufacturer.

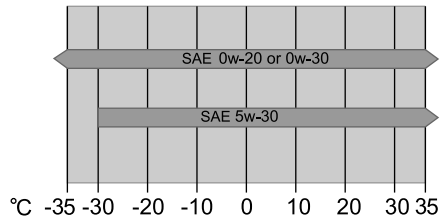

# Maintenance

---

## Engine Oil Level Check and Top Up



*Driving the vehicle with the engine oil level ABOVE the upper mark, or BELOW the lower mark on the dipstick, will damage the engine. Take care to avoid spilling engine oil onto a hot engine – a fire may result!*

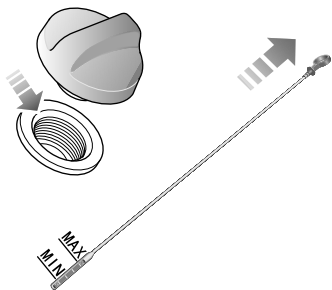

1.3L Turbocharged Engine

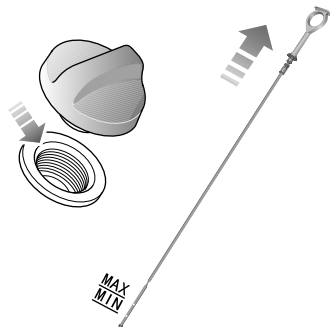

1.5L Engine

# Maintenance

---

Check the oil level weekly and top up with oil when necessary. Ideally, the oil level should be checked with the engine cold and the car resting on level ground. However, if the engine is running and already getting warm, wait for at least five minutes after switching off the START/STOP Switch before checking the level.

- 1 Withdraw the dipstick and wipe off the oil on it.
- 2 Slowly insert the oil dipstick and pull it out again to check the oil level; the oil level shall not be lower than the "MIN" mark on the oil dipstick.
- 3 Screw off the oil filler cap and refill the oil to maintain the oil level between the "MAX" mark and "MIN" mark on the oil dipstick.
- 4 Wait for 5 minutes and then recheck the oil level, add an appropriate amount of oil if necessary – DO NOT OVERFILL!
- 5 Finally, ensure the dipstick is inserted and oil filler cap is fully secured.

## Engine Oil Specification

Use the engine oil recommended and certified by the manufacturer. Refer to "Recommended Fluids and Capacities" in "Technical Data" section.

**Note: Do not use the oil additives not applicable to the car, or else the engine may be damaged. You are recommended to use the oil additives certified by the manufacturer, please consult your local Authorised Repairer for details.**

IMPORTANT
Check the engine oil more frequently if the vehicle is driven at high speeds for prolonged periods.

## Cooling System

### Coolant Check and Top Up



**DO NOT remove the engine coolant reservoir cap when the cooling system is hot - escaping steam or hot coolant could cause serious injury.**

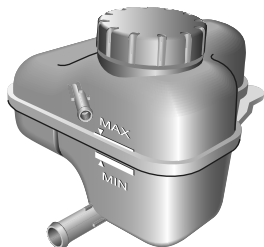

It is recommended that the cooling system should be checked weekly when the cooling system is cold and with the car resting on level ground. If the level is below the 'MIN' mark, remove the expansion tank cap and top up coolant, the level must not be higher than 'MAX' mark.

**Note: Prevent coolant coming into contact with the vehicle body when topping up. Coolant will damage paint.**

If the coolant level falls appreciably during a short period, the cooling system leakage may occur, please have it serviced in time by a local MG Authorised Repairer.

### Coolant Specification

Please use the coolant recommended and certified by the manufacturer. Refer to 'Recommended Fluids and Capacities' in "Technical Data" chapter.

**Note: In an emergency, top up the coolant reservoir with a small amount of clean water. However, it should be noted that this will weaken the anti-freeze and anti-corrosion protection and reduce the service life of the coolant. DO NOT refill the cooling system with anti-freeze of different formulations.**

**Note:** *The addition of corrosion inhibitors or other additives to the cooling system of this car may severely disrupt the efficiency of the system and cause engine damage. For cooling system issues please consult an MG Authorised Repairer.*

### Antifreeze Fluid



*Coolant is poisonous and can be fatal if swallowed - keep coolant containers sealed and out of the reach of children. If accidental contact of coolant by children is suspected, seek medical assistance immediately.*



*Prevent coolant coming into contact with the skin or eyes. If this occurs, rinse immediately with plenty of water. If eyes are still red, painful or uncomfortable, seek medical attention immediately.*

## Brake

### Brake Pads



**DO NOT rest your foot on the brake pedal while driving; this may overheat the brakes, reduce their efficiency and cause excessive wear.**

For the first 1500 km, you should avoid situations where heavy braking is required.

Remember that regular servicing is vital to ensure that all the brake components are examined for wear at the correct intervals, and replaced when required to ensure long term safety and optimum performance during the interval prescribed in Service Portfolio.

The car needs to run in for 800 km after the brake pad or disc is replaced.

### Brake Fluid Check and Top Up



**Brake fluid is highly toxic, keep containers sealed and out of the reach of children. If accidental contact of brake fluid is suspected, seek medical attention immediately.**



**Prevent brake fluid coming into contact with the skin or eyes. If this occurs, rinse immediately with plenty of water. If eyes are still red, painful or uncomfortable, seek medical attention immediately.**

The brake fluid level should be checked weekly when the system is cold and with the car on level ground.

The fluid level can be seen through the reservoir neck and should be maintained as close to the "MAX" mark as possible. Do not allow the level to drop below the "MIN" mark.

**Note: Brake fluid will damage painted surfaces. If you accidentally spill the brake fluid on the painted surface, soak up any spillage with an absorbent cloth**

# Maintenance

*immediately and wash the area with water or car shampoo.*

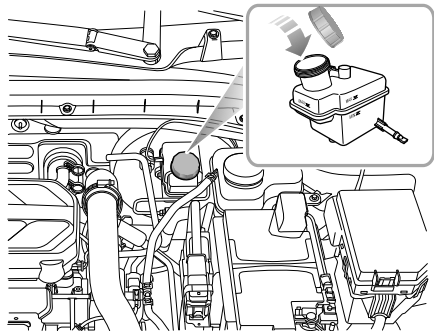

## IMPORTANT

Replace brake fluid regularly according to the Service Portfolio.

## Brake Fluid Specification

Use the brake fluid recommended and approved by the manufacturer. Refer to "Recommended Fluids and Capacities" in the "Technical Data" section.

## Battery

### Battery Maintenance



***DO NOT leave electric components switched on when the engine is not running, the battery may become flat and you will not be able to start the engine.***

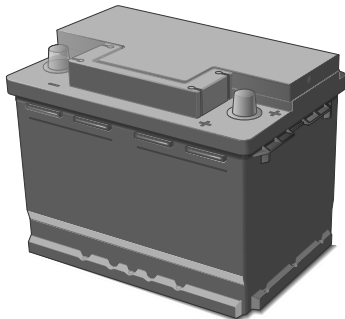

You can see the battery when you open the engine compartment. The battery is maintenance-free type, therefore there is no need to refill fluid.

For different battery types equipped, on the top of some batteries there is a battery condition indicator. Examine the indicator periodically to check the battery's condition. When the indicator shows:

- GREEN - the battery is in a good state of charge.
- DARK (turning to black) - the battery needs charging.
- CLEAR (or light yellow) - the battery must be replaced.

***Note: Please ensure a clear view of the condition indicator. Use a torch if natural light is poor.***

***Note: If the vehicle is stored for more than 1 month, remove the negative terminal from the battery. Make sure that the START/STOP switch has been turned off before connecting or disconnecting the negative terminal.***

### Battery Replacement



***The battery contains sulphuric acid, which is corrosive.***



## Maintenance

---

The battery contains sulphuric acid, which is corrosive. Please go to an MG Authorised Repairer to remove and install the battery. Only fit a replacement battery of the same type and specification as the original to maintain the correct vehicle functionality.



The battery must be disposed of using an approved method, used batteries can be harmful to the environment. It should be recycled by a professional company. Please consult an MG Authorised Repairer for more details.

# Maintenance

## Washers

### Windscreen Washer Check and Top Up



When filling the washer fluid, **DO NOT** let the washer fluid spill on parts in the compartment or on the paint surface of vehicle body. In case the washer fluid is spilled on hands or other parts of the body, please immediately wash with clean water.

Check the washer fluid level regularly. When the level of washer fluid is low, please top up the washer fluid as instructed.

**Note:** *DO NOT use anti-freeze or vinegar/water solution in the washer reservoir - anti-freeze will damage paintwork while vinegar will damage the washer pump.*

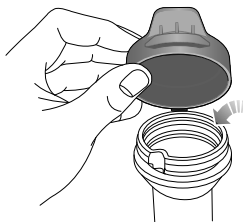

#### IMPORTANT

- Use the washer fluid recommended and certified by the manufacturer. Misuse of washer fluid in winter may cause damage to the washer pump due to freezing.
- Using the washers when there is no washer fluid may cause damage to the washer pump.
- Operating the wipers when the windshields are dry and there is no washer fluid may cause damage to the windshields and wipers. Please spray the washer fluid and start the wipers when there is adequate washer fluid.

## **Washer Nozzles**

Operate the washers periodically to check that the nozzles are clear and properly directed.

If the nozzle is obstructed, insert a needle or thin metal wire into the hole to remove the obstruction.

## **Washer Fluid Specification**

Use the washer fluid recommended and certified by the manufacturer. Refer to 'Recommended Fluids and Capacities'.

# Maintenance

---

## Wipers

### Wiper Blades

#### IMPORTANT

- Grease, silicon and petrol based products impair the blade's wiping capability. Wash the wiper blades in warm soapy water and periodically check their condition.
- Clean the windscreen frequently, DO NOT use wipers to remove stubborn or ingrained dirt, it will reduce their effect and their life span.
- If signs of hardness or cracking in the rubber are found, or if the wipers leave streaks or unwiped areas on the screen, then the wiper blades should be replaced.
- Clean the windscreen regularly with an approved glass cleaner and ensure the screen is thoroughly cleaned before fitting replacement wiper blades.
- Only fit replacement wiper blades that are identical to the original specification.
- Clean ice and snow from around wipers and ensure they are not frozen or otherwise sticking to the windscreen before attempting to operate them.

### Replacing Front Wiper Blades

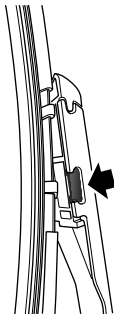

- 1 With the bonnet closed, and within 20 seconds of switching the vehicle power system to the OFF position, operate the wiper stalk switch by pressing down and releasing, the wipers will sweep and stop in the 'service position' on the windscreen.
- 2 Lift the wiper arm away from the windscreen.
- 3 Press the retaining clips at both sides (as shown in the figure), whilst pulling the wiper blade outward, to remove the wiper blade from the wiper arm and discard.
- 4 Position the fitting of the new wiper blade into the slot of the wiper arm.
- 5 Push the wiper blade towards the wiper arm until it is located embedded with a click been heard.
- 6 Place the wiper assembly back on the windscreen.
- 7 To exit the service mode and return the wipers to the park position, operate the wiper stalk switch again by pressing down and releasing, alternatively, switch the vehicle power system to the ON position.

## Replacing Rear Wiper Blades

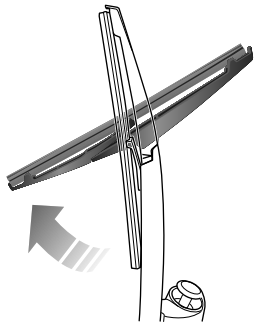

- 1 Lift the wiper arm away from the rear window.
- 2 Rotate the wiper blade as shown in the figure, to remove it from the wiper arm and discard.
- 3 Position the fitting of the new wiper blade into the slot of the wiper arm. Ensure the wiper blade is properly secured on the wiper arm.
- 4 Place the wiper assembly back on the rear window.

## Tyres

### Overview

- Take extra care when using new tyres for the first 300 miles (500 kilometres).
- Avoid excessive cornering at speed.
- Slow down when passing through road shoulder or a similar section, and allow the wheels to go through the shoulder at the right angle as far as possible.
- Regularly check the damage of tyres (stabs, scratches, cracks and pits) and remove any foreign objects from the tread.
- Prevent the tyre from contacting oil, grease and fuel.
- Ensure valve caps are always fitted.
- If the tyre is to be removed always mark the tyre/wheel orientation to ensure correct reinstallation.
- The wheels or tyres that have been disassembled should be kept in a cool, dry and light-free place.

### New Tyres

New tyres may not have the best adhesive ability at the beginning. Therefore, driving your vehicle at moderate

speed and in a prudent way at the first 300 miles (500 kilometres), which is also beneficial to the service life of the tyres.

The damage of tyre or rim may happen unnoticed. If abnormal vibration or handling is experienced, that means the tyre or rim may have been damaged. Please slow down and park your vehicle in absolute safety, then check the tyre and rim. If you can't see the damage from the outside, you should continue to drive with low speed and go to the nearest MG Authorised Repairer for inspection.

### Directional Tyres

Directional tyres are marked with 'direction of rotation' (DOR). To maintain handling characteristics, tyre performance, low road noise and extend tyre life, tyres must always be fitted with indication arrow showing the correct 'DOR'.

### Tyre Life

Correct tyre pressure and moderate driving style can extend tyre life.

Recommendations:

# Maintenance

---

- If the vehicle is to be stored for a lengthy time, please move your vehicle at least once in two weeks to 'rotate the tyres'.
- Check the pressure of tyres regularly when they are cold.
- Avoid cornering at excessive speed.
- Regularly check tyres for abnormal wear patterns.

These following factors may affect the tyre life.

## Tyre Pressure

Incorrect pressure will cause the abnormal wear of the tyre, greatly shorten the service life, and have an adverse effect on the driving characteristics of the vehicle. Tyre pressure should be checked at least once a month, and once prior to each long-distance journey.

## Driving Style

Excessively harsh acceleration and braking ( you may hear a piercing noise) or driving at high speed whilst cornering will increase the wear of tyre.

## Wheel Balance

The working balance of auto-wheels is well tested before a new vehicle comes out of the factory. But the wheels may be out of balance due to many factors.

If wheels are out of balance, shaking or vibration of the steering mechanism may occur and the tyres may be excessively worn. It is important to rectify this quickly. Each wheel should be rebalanced after installing a new tyre or having the tyre repair.

## Wheel Alignment

Incorrect wheel alignment can cause excessive tyre wear and affect vehicle safety. If the tyres show signs of abnormal wear, seek advice from an MG Authorised Repairer.

## Caring for Your Tyres



**DEFECTIVE TYRES ARE DANGEROUS!**  
**DO NOT drive if any tyre is damaged, is excessively worn, or is inflated to an incorrect pressure.**



Always drive with consideration for the condition of the tyres, and regularly inspect the tread and side walls for any sign of distortion (bulges), cuts or wear.

**Note: If possible, protect tyres from contamination by oil, grease and fuel.**

## Tyre Pressure



**Before a long distance journey, the tyre pressure must be checked.**

Check the pressure (including the spare wheel) at least once a month, when the tyres are cold.

If it is necessary to check the tyre pressure when they are warm, you should expect the pressure to have increased by 0.3 to 0.4 bar (4.35 to 5.8 psi). In this circumstance, NEVER let air out of the tyres in order to match the recommended pressure (cold).

## Valves

Keep the valve caps screwed down firmly - they prevent dirt from entering the valve. Check the valve for leaks (listen for a tell-tale hissing) when you check the tyre pressure.

## Punctured Tyres

If a sharp object penetrates the tyre and remains in it, the tyre may not leak. If you are aware of this occurring, reduce speed immediately and drive with caution until the spare wheel can be fitted, or repairs undertaken.

**Note: If the sidewall of the tyre is damaged or distorted, replace the tyre immediately, do not attempt a repair.**

## Tyre Wear Indicators

At the bottom of the original tyre, there is a 1.6 millimeter high wear mark perpendicular to the wheel rolling direction. These indicators moulded into the tread pattern at several points around the circumference. A mark on the side of a tyre, such as the upper case letter TWI or the triangle, indicating the position of the wear mark.

When the tread has worn down to 1.6 millimeter, the indicators will come to the surface of the tread pattern, producing the effect of a continuous band of rubber across the width of the tyre.

# Maintenance

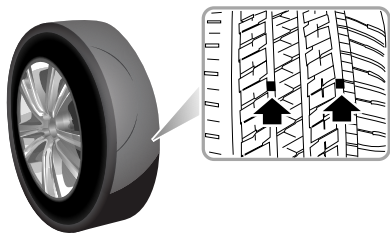

## IMPORTANT

A tyre **MUST** be replaced as soon as a wear indicator becomes visible.

## Replacement Tyres



*It is recommended to install the tyres consistent with the original specifications. **DO NOT** replace the tyres with tyres of any other type. Alternative tyres, of a different specification, may adversely affect the vehicle's driving characteristics and safety. In order to make your driving and safety better guarantee, it is suggested that you consult an **MG Authorised Repairer**.*

Always have replacement wheels and tyres balanced before use.

## Wheel Fitment Rotation

It is not recommended that you swap wheels from side to side or front to rear in order to equalise tyre wear. Your vehicle is fitted with Tyre Pressure Monitoring System which means that each wheel is programmed to the relative position.

## Maintenance

---

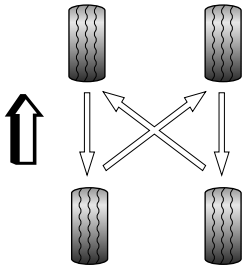

If you do wish to swap wheels and tyres around on the vehicle please consult an MG Authorised Repairer as extra coding will be required.

### Snow Chains

Unsuitable snow chains could damage the tyres, wheels, suspension, brakes or bodywork of your car.

Please pay attention to the following requirements in the usage:

- The tyre/snow chains can only be fitted on the front wheels;
- The thickness of tyre/snow chains shall not exceed 15 mm;
- Please always observe the installation and tension instructions for the tyre/snow chains, as well as the speed limitations of different roads;
- DO NOT drive faster than 30 mph (50 km/h) ;
- To avoid the tyre damage and excessive wear of the tyre/snow chains, the tyre/snow chains must be removed while driving on the road without snow.

**The wheel and tyre specifications for the tyre/snow chains apply to this model are as follows:**

Wheel rim size: 6.5J×16

Tyre size: 205/60 R16

**Note:** *Snow chains are only allowed to be fitted to tyres of the specifications recommended by the manufacturer.*

## Maintenance

---

***Note: If you drive on roads covered with snow or ice, it is recommended to use winter tyres. Consult an MG Authorised Repairer for details.***

## Cleaning and Vehicle Care



*Observe all safety precautions on cleaning products; do not drink fluids and keep them away from the eyes.*

## External Car

### Washing Your Car



*Some high pressure cleaning systems will penetrate door, window and sunroof seals, and damage lock mechanisms. DO NOT aim water jets directly at components that might be easily damaged.*



*Do not clean the engine compartment with high pressure water since it may damage the electrical system of the vehicle.*

In order to preserve the paint finish on your car, please observe the following care points:

- DO NOT use hot water to wash the car.
- DO NOT use detergents or washing up liquid.
- In hot weather, DO NOT wash the car in direct sunlight.

- When using a hose, DO NOT aim the water directly at window, door or sunroof seals, or through wheel apertures onto the brake components.

If the car is particularly dirty, use a hose to flush grime and grit from the bodywork, prior to washing. Then, wash the car using cold or lukewarm water containing a good quality wash and wax shampoo. Always use plenty of water to ensure that grit is flushed from the surface and not ground into the paintwork. After washing, rinse the bodywork with clean water and dry off with a chamois leather.

### *Cleaning the underside*

**Note:** *DO NOT use a high pressure hose to clean the engine compartment – damage to the car's electronic systems may occur.*

From time to time, but particularly during winter months when salt has been used on the roads, use a hose to wash the underside of the car. Flush away accumulations of mud and thoroughly clean those areas where debris can easily collect (wheel arches and panel seams, for example).

# Maintenance

## IMPORTANT

- Avoid cleaning the vehicle in direct sunlight.
- When cleaning the vehicle in winter avoid spraying water directly onto door locks and panel gaps due to risk of icing.
- Do not use rough sponges or cloth to clean the car, this will damage the paintwork finish.
- When cleaning the headlamps do not use a dry cloth or sponge, use only warm soapy water.

### *Cleaning with a High Pressure Cleaner*

**Note:** Always read the manufacturers operating instructions.

When using high pressure washers, always ensure there is adequate distance between the spray nozzle and any soft materials, decals or rubber seals.

## IMPORTANT

- Please pay attention to the operating instructions of high pressure cleaner.
- Soft parts on the vehicle should be kept in a large enough distance from the high pressure cleaner.

### **Removing tar spots**

Use white spirit to remove tar spots and stubborn grease stains from the paintwork. Then wash the area immediately with soapy water to remove all traces of the spirit.

### **Body Protection**

After washing, examine the paintwork for damage. If the damage has revealed bare metal, use a colored primer first, then apply the correct colour base coat and finish off with a lacquer pencil, if appropriate. Carry out this treatment after washing but before polishing or waxing. More extensive damage to paint or bodywork must be repaired in accordance with the manufacturer's recommendations. Failure to do this will invalidate the Anti-Corrosion Warranty. If in doubt, ask your MG Authorised Repairer.

## Polishing the Paintwork



**DO NOT use car polish containing coarse abrasives – these will remove the paint film and damage the gloss finish.**

Occasionally treat the paint surface with an approved polish containing the following properties:

- Very mild abrasives to remove surface contamination without removing or damaging the paint.
- Filling compounds that will fill scratches and reduce their visibility.
- Wax to provide a protective coating between the paint and the elements.

**Note: If possible, avoid applying polish or wax products to window glass and rubber seals.**

## Wiper Blades

Wash in warm soapy water. DO NOT use spirit or petrol based cleaners.

## Windows and Mirrors

Regularly clean all windows, inside and out, using an approved glass cleaner.

**Windscreen:**In particular, clean the outside of the screen with glass cleaner after washing the car with wash and wax products, and before fitting new wiper blades.

**Rear screen:**Clean the inside with a soft cloth, using a side to side motion to avoid damaging the heating elements.

**Note: DO NOT scrape or use abrasive cleaners on the inside of the rear screen – this will damage the heating elements.**

**Mirrors:**Wash with soapy water. Use a plastic scraper to remove ice. DO NOT use abrasive cleaning compounds or metal scraper.

## Plastic Components

Any plastic components should be cleaned using conventional cleaning methods and not be treated with abrasive materials.

# Maintenance

---

## Paint Damage

Any paint damage or stonechips should be treated with suitable paint/lacquer materials immediately to avoid invalidating the Anti Corrosion Warranty.

## Weather Strips and Rubber Seals

Any weather strips or rubber aperture seals should be treated with suitable materials (silica gel) if they are cleaned using strong detergents, this should avoid any sticking and maintain the service life of the seal.

## Wheels



***When cleaning the wheels any materials or water that contact the brake disc directly may effect braking efficiency.***

In order to ensure the wheels are kept in optimum condition they should be cleaned regularly.

Only use a recommended non-acidic propriety wheel cleaner. Always read the instructions on the product.

## Cleaning the Interior

### Plastic materials

Clean plastic-faced materials with diluted upholstery cleaner, then wipe with a damp cloth.

***Note: DO NOT polish dashboard components – these should remain non-reflective.***

### Carpet and fabrics

Clean with diluted upholstery cleaner - test a concealed area first.

### Leather

Clean leather trim with warm water and a non-detergent soap. Dry and polish the leather with a dry, clean, lint-free cloth.

***Note: DO NOT use petrol, detergents, furniture creams or polishes as cleaning agents.***

### Instrument Pack, Audio and Navigation Display

Clean with a dry cloth only. DO NOT use cleaning fluids or sprays.



## Airbag Module Covers



***DO NOT allow these areas to be flooded with liquid and DO NOT use petrol, detergent, furniture cream or polishes.***

To protect damage to the airbag SRS, the following areas should be cleaned sparingly with a damp cloth and upholstery cleaner ONLY:

- Steering wheel centre pad.
- Area of dashboard containing the passenger airbag.
- Area of roof lining and front pillar finishers which enclose the side head impact protection modules.

## Seat Belts



***DO NOT use bleaches, dyes or cleaning solvents on seat belts.***

Extend the belts, then use warm water and a non-detergent soap to clean. Allow the belts to dry naturally; **DO NOT** retract them or use the car until they are completely dry.



## **Technical Data**

---

*274 Technical Data Dimensions*

*276 Weights*

*277 Major Parameters of Engine*

*279 Dynamic Performance Parameters*

*280 Recommended Fluids and  
Capacities*

*282 Four-Wheel Alignment Parameter  
Table (Unladen)*

*282 Wheels and Tyres*

*282 Tyre Pressure (Cold)*

# Technical Data

## Technical Data Dimensions

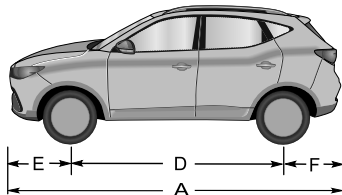
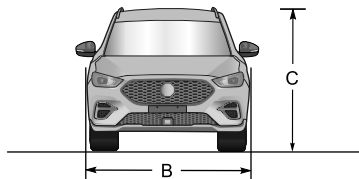

Item, Units	Parameter
Overall length A, mm	4323
Overall width B, mm	1809
Overall height C (unladen), mm	1628(excluding luggage rack ) /1653(including luggage rack )
Wheelbase D, mm	2585
Front Overhang E , mm	901
Rear Overhang F , mm	837

## Technical Data

Item, Units	Parameter
Front wheel track, mm	1526
Rear wheel track, mm	1539
Minimum ground clearance (laden), mm	144.6
Minimum turning circle diameter, m	11.2
Fuel tank capacity, l	45/48

**Note:** Vehicle length measurement, including all parts that meet GB1589 measurement requirement at delivery while not including the license plate.

**Note:** Rearview mirrors and the deformed portion of tyre wall directly above the touchdown point are not included in the total width.

## Technical Data

### Weights

Item, Units	Parameter		
	1.3T 6AT	1.5L 5MT	1.5L CVT
Person in cab, person	5		
Unladen vehicle weight, kg	1318	1258	1318
Gross vehicle weight, kg	1750	1690	1750
Unladen front axle weight, kg	796	751	796
Unladen rear axle weight, kg	522	507	522
Gross front axle weight, kg	903	857	903
Gross rear axle weight, kg	847	833	847

## Technical Data

### Major Parameters of Engine

Vehicle	Parameters
	I.3T
Bore × stroke, mm × mm	80×89.4
Total displacement, L	1.349
Compression ratio	10:1
Maximum net power, KW	115
Rated power, KW	120
Engine speed at rated power, rev/min	5200–5600
Maximum torque, Nm	230
Engine speed at maximum torque, rev/min	1800–4400
Idle speed, rev/min	830
Fuel grade, RON	RON 95 and above unleaded gasoline

## Technical Data

Vehicle	Parameters
	1.5L
Bore × stroke, mm × mm	75×84.8
Total displacement, L	1.498
Compression ratio	11.5:1
Maximum net power, KW	84
Rated power, KW	88
Engine speed at rated power, rev/min	6000
Maximum torque, Nm	150
Engine speed at maximum torque, rev/min	4500
Idle speed, rev/min	680
Fuel grade ( Middle East ) , RON	RON 91 and above unleaded gasoline
Fuel grade ( South America ) , RON	RON 92 and above unleaded gasoline



## Technical Data

### Dynamic Performance Parameters

Item, Units	Parameter		
	1.3T 6AT	1.5L 5MT	1.5L CVT
Acceleration, s (0-100) km/h	9.8	11.9	12.8
Maximum speed, km/h	185	175	170
Gradeability, %	30	30	30

**Note:** *The dynamic performance parameters are test data under specific conditions.*

**Note:** *Gradeability is effected by different road surface, tire pressure, tire tread depth, vehicle load.*

## Technical Data

### Recommended Fluids and Capacities

Name	Grade	Capacity		
		1.5L-5MT	1.5L-CVT	1.3T-6AT
Engine oil (after-sales replacement), l	A5/B5 5W-30 C5 0W-20	4.1		—
	SN/GF-5 5W-30 C3 5W-30	—		4.6
Engine coolant, l	Glycol (OAT)	5.4		6.4
Automatic transmission fluid, l	AW-1	—		6.2
Continuously variable automatic transmission fluid, l	Shell-2100	—	6.96	—
Manual transmission oil, l	BOT503	1.7	—	
Brake fluid, l	DOT 4	0.75		

## Technical Data

Washer fluid, l	ZY-VIII	4
Air conditioning refrigerant, g	R134a	540±20

## Technical Data

**Four-Wheel Alignment Parameter Table (Unladen)**

Item		Parameter
Front	Camber angle	$-0^{\circ}36\phi \pm 45\phi$
	Castor angle	$4^{\circ}02\phi \pm 45\phi$
	Toe-in angle (Total Toe-in)	$0^{\circ}8\phi \pm 15\phi$
	Kingpin Inclination angle	$12^{\circ}05\phi \pm 45\phi$
Rear	Camber angle	$-1^{\circ}15\phi \pm 45\phi$
	Toe-in angle (Total Toe-in)	$0^{\circ}25\phi \pm 20\phi$

### Wheels and Tyres

Wheel size	7J×17	6.5J×16
Tyre size	215/55 R17	205/60 R16

### Spare Tyre

Wheel Rim Specification	4J×16
Spare Tyre Specification	T125/90 R16

### Tyre Pressure (Cold)

Wheels	Unladen
Front Wheels	230kPa/2.3bar/34psi
Rear Wheels	230kPa/2.3bar/34psi
Spare Tyre	420kPa/4.2bar/60psi